

1/8 ELECTRIC OFF-ROAD BUGGY

# XRAY XB8E

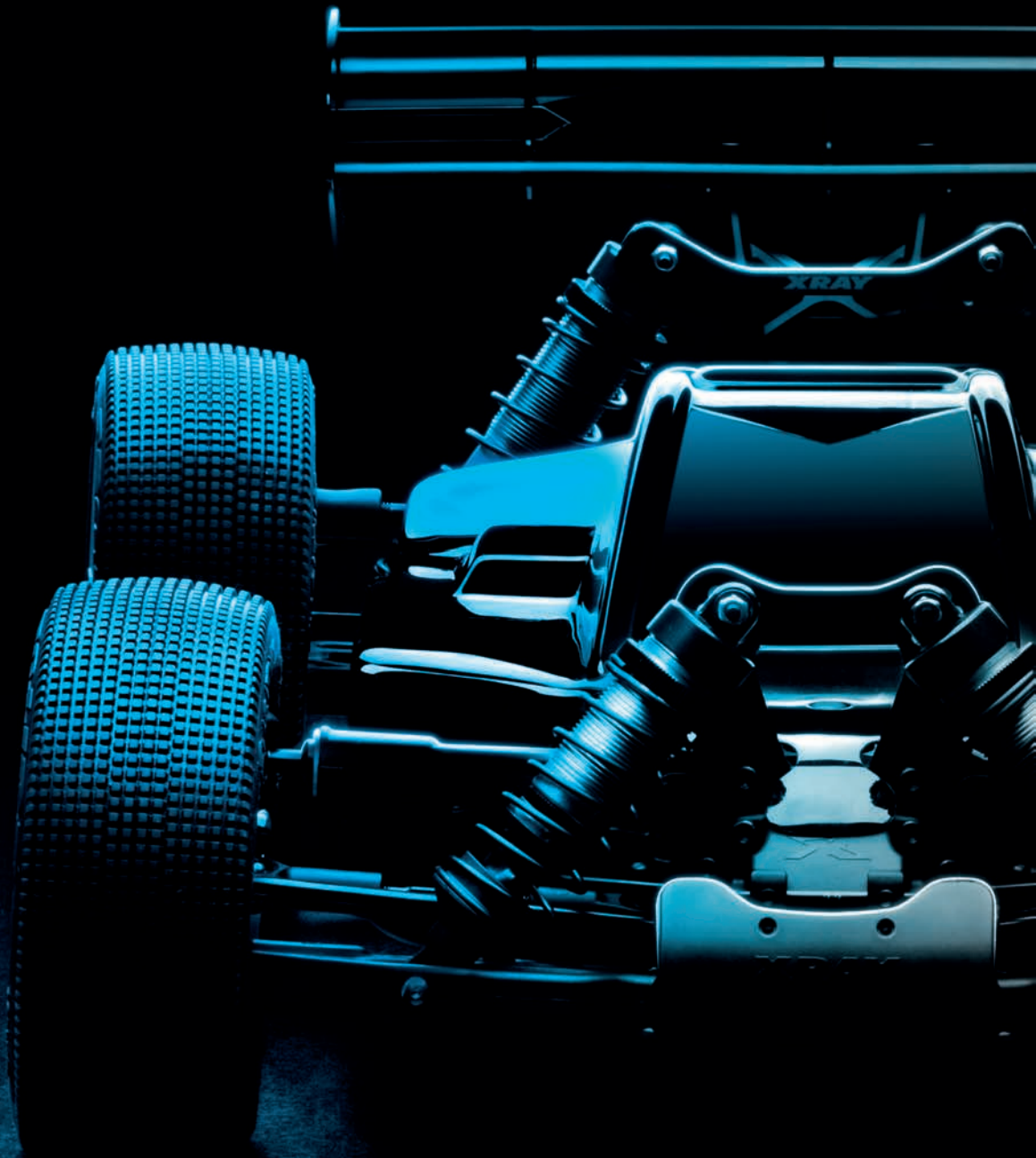

**INSTRUCTION MANUAL**

**XRAY XB8E'26**

## BEFORE YOU START

This is a high-competition, high-quality RC car intended for persons aged 16 years and older with previous experience building and operating RC model racing cars. This is NOT a toy; it is a precision racing model. This model racing car is not intended for use by beginners, inexperienced customers, or by children without direct supervision of a responsible, knowledgeable adult. If you DO NOT fulfill these requirements, please return the kit in unused and unassembled form back to the shop where you have purchased it.

Before building and operating your XRAY, **YOU MUST** read through all of the operating instructions and instruction manual and fully understand them to get the maximum enjoyment and prevent unnecessary damage.

## CUSTOMER SUPPORT

We have made every effort to make these instructions as easy to understand as possible. However, if you have any difficulties, problems, or questions, please DO NOT hesitate to contact the XRAY support team at [info@teamxray.com](mailto:info@teamxray.com). Also, please visit our Web site at [www.teamxray.com](http://www.teamxray.com) to find the latest updates, set-up information, option parts, and many other goodies. We pride ourselves on taking excellent care of our customers.

You can join thousands of XRAY fans and enthusiasts in our online community at: [www.teamxray.com](http://www.teamxray.com)

Read carefully and fully understand the instructions before beginning assembly.

Make sure you review this entire manual, download and use set-up book from the web, and examine all details carefully. If for some reason you decide this is not what you wanted or expected, **DO NOT continue any further**. Your hobby dealer can not accept your kit for return or exchange after it has been partially or fully assembled.

Contents of the box may differ from pictures. In line with our policy of continuous product development, the exact specifications of the kit may vary without prior notice.

### XRAY Europe

K Vystavisku 6992  
91101 Trenčín  
Slovakia, EUROPE  
Phone: 421-32-7401100  
Fax: 421-32-7401109  
E-mail: [info@teamxray.com](mailto:info@teamxray.com)

### XRAY USA

RC America, 2030 Century Center Blvd #15 Irving, TX  
75062  
USA  
Phone: (214) 744-2400  
Fax: (214) 744-2401  
E-mail: [xray@rcamerica.com](mailto:xray@rcamerica.com)

## FAILURE TO FOLLOW THESE INSTRUCTIONS WILL BE CONSIDERED AS ABUSE AND/OR NEGLIGENCE.

## SAFETY PRECAUTIONS

Contains:

LEAD (CAS 7439-92-1) ANTIMONY (CAS 7440-36-0)

WARNING: This product contains a chemical known to the state of California to cause cancer and birth defects or other reproductive harm.

CAUTION: CANCER HAZARD

Contains lead, a listed carcinogen. Lead is harmful if ingested. Wash thoroughly after using. DO NOT use product while eating, drinking or using tobacco products. May cause chronic effects to gastrointestinal tract, CNS, kidneys, and blood. MAY CAUSE BIRTH DEFECTS.

When building, using and/or operating this model always wear protective glasses and gloves.

Take appropriate safety precautions prior to operating this model. You are responsible for this model's assembly and safe operation! Please read the instruction manual before building and operating this model and follow all safety precautions. Always keep the instruction

manual at hand for quick reference, even after completing the assembly. Use only genuine and original authentic XRAY parts for maximum performance. Using any third party parts on this model will void warranty immediately.

Improper operation may cause personal and/or property damage. XRAY and its distributors have no control over damage resulting from shipping, improper construction, or improper usage. XRAY assumes and accepts no responsibility for personal and/or property damages resulting from the use of improper building materials, equipment and operations. By purchasing any item produced by XRAY, the buyer expressly warrants that he/she is in compliance with all applicable federal, state and local laws and regulation regarding the purchase, ownership and use of the item. The buyer expressly agrees to indemnify and hold harmless XRAY for all claims resulting directly or indirectly from the purchase, ownership or use of the product. By the act of assembling or operating this product, the user accepts all resulting liability. If the buyer is not prepared to accept this liability, then he/she should return this kit in new, unassembled, and unused condition to the place of purchase.



## IMPORTANT NOTES - GENERAL

- This product is not suitable for children under 16 years of age without the direct supervision of a responsible and knowledgeable adult.
- Carefully read all manufacturers warnings and cautions for any parts used in the construction and use of your model.
- Assemble this kit only in places away from the reach of very small children.
- First-time builders and users should seek advice from people who have building experience in order to assemble the model correctly and to allow the model to reach its performance potential.
- Exercise care when using tools and sharp instruments.
- Take care when building, as some parts may have sharp edges.
- Keep small parts out of reach of small children. Children must not be allowed to put any parts in their mouth, or pull vinyl bag over their head.
- Read and follow instructions supplied with paints and/or cement, if used (not included in kit).
- Immediately after using your model, DO NOT touch equipment on the model such as the motor and speed controller, because they generate high temperatures. You may seriously burn yourself seriously touching them.
- Follow the operating instructions for the radio equipment at all times.
- DO NOT put fingers or any objects inside rotating and moving parts, as this may cause damage or serious injury as your finger, hair, clothes, etc. may get caught.
- Be sure that your operating frequency is clear before turning on or running your model, and never share the same frequency with somebody else at the same time. Ensure that others are aware of the operating frequency you are using and when you are using it.
- Use a transmitter designed for ground use with RC cars. Make sure that no one else is using the same frequency as yours in your operating area. Using the same frequency at the same time, whether it is driving, flying or sailing, can cause loss of control of the RC model, resulting in a serious accident.
- Always turn on your transmitter before you turn on the receiver in the car. Always turn off the receiver before turning your transmitter off.
- Keep the wheels of the model off the ground when checking the operation of the radio equipment.
- Disconnect the battery pack before storing your model.
- When learning to operate your model, go to an area that has no obstacles that can damage your model if your model suffers a collision.
- Remove any sand, mud, dirt, grass or water before putting your model away.
- If the model behaves strangely, immediately stop the model, check and clear the problem.
- To prevent any serious personal injury and/or damage to property, be responsible when operating all remote controlled models.
- The model car is not intended for use on public places and roads or areas where its operation can conflict with or disrupt pedestrian or vehicular traffic.
- Because the model car is controlled by radio, it is subject to radio interference from many sources that are beyond your control. Since radio interference can cause momentary loss of control, always allow a safety margin in all directions around the model in order to prevent collisions.
- DO NOT use your model:
  - Near real cars, animals, or people that are unaware that an RC car is being driven.
  - In places where children and people gather
  - In residential districts and parks
  - In limited indoor spaces
  - In wet conditions
  - In the street
  - In areas where loud noises can disturb others, such as hospitals and residential areas.
  - At night or anytime your line of sight to the model may be obstructed or impaired in any way.

To prevent any serious personal injury and/or damage to property, please be responsible when operating all remote controlled models.

## **IMPORTANT NOTES – ELECTRICAL**

- Insulate any exposed electrical wiring (using heat shrink tubing or electrical tape) to prevent dangerous short circuits. Take maximum care in wiring, connecting and insulating cables. Make sure cables are always connected securely. Check connectors for if they become loose. And if so, reconnect them securely. Never use RC models with damaged wires. A damaged wire is extremely dangerous, and can cause short-circuits resulting in fire. Please have wires repaired at your local hobby shop.
- Low battery power will result in loss of control. Loss of control can occur due to a weak battery in either the transmitter or the receiver. Weak running battery may also result in an out of control car if your car's receiver power is supplied by the running battery. Stop operation immediately if the car starts to slow down.
- When not using RC model, always disconnect and remove battery.
- DO NOT disassemble battery or cut battery cables. If the running battery short-circuits, approximately 300W of electricity can be discharged, leading to fire or burns. Never disassemble battery or cut battery cables.
- Use a recommended charger for the receiver and transmitter batteries and follow the instructions correctly. Over-charging, incorrect charging, or using inferior chargers can cause the batteries to become dangerously hot. Recharge battery when necessary. Continual recharging may damage battery and, in the worst case, could build up heat leading to fire. If battery becomes extremely hot during recharging, please ask your local hobby shop for check and/or repair and/or replacement.
- Regularly check the charger for potential hazards such as damage to the cable, plug, casing or other defects. Ensure that any damage is rectified before using the charger again. Modifying the charger may cause short-circuit or overcharging leading to a serious accident. Therefore DO NOT modify the charger.
- Always unplug charger when recharging is finished.
- DO NOT recharge battery while battery is still warm. After use, battery retains heat. Wait until it cools down before charging.
- DO NOT allow any metal part to short circuit the receiver batteries or other electrical/electronic device on the model.
- Immediately stop running if your RC model gets wet as may cause short circuit.
- Please dispose of batteries responsibly. Never put batteries into fire.

## **R/C & BUILDING TIPS**

- Make sure all fasteners are properly tightened. Check them periodically.
- Make sure that chassis screws DO NOT protrude from the chassis.
- For the best performance, it is very important that great care is taken to ensure the free movement of all parts.
- Clean all ball-bearings so they move very easily and freely.
- Tap or pre-thread the plastic parts when threading screws.

- Self-tapping screws cut threads into the parts when being tightened. DO NOT use excessive force when tightening the self-tapping screws because you may strip out the thread in the plastic. We recommended you stop tightening a screw when you feel some resistance.
- Ask your local hobby shop for any advice.

Please support your local hobby shop. We at XRAY Model Racing Cars support all local hobby dealers. Therefore we ask you, if at all possible, to purchase XRAY products at your hobby dealer and give them your support like we do. If you have difficulty finding XRAY products, please check out [www.teamxray.com](http://www.teamxray.com) to get advice, or contact us via email at [info@teamxray.com](mailto:info@teamxray.com), or contact the XRAY distributor in your country.

## **WARRANTY**

XRAY guarantees this model kit to be free from defects in both material and workmanship within 30 days of purchase. The total monetary value under warranty will in no case exceed the cost of the original kit purchased. This warranty DOES NOT cover any components damaged by use or modification or as a result of wear. Part or parts missing from this kit must be reported within 30 days of purchase. No part or parts will be sent under warranty without proof of purchase. Should you find a defective or missing part, contact the local distributor. Service and customer support will be provided through local hobby store where you have purchased the kit, therefore make sure to purchase any XRAY products at your local hobby store. This model racing car is considered to be a high-performance racing vehicle. As such this vehicle will be used in an extreme range of conditions and situations, all which may cause premature wear or failure of any component. XRAY has no control over usage of vehicles once they leave the dealer, therefore XRAY can only offer warranty against all manufacturer's defects in materials, workmanship, and assembly at point of sale and before use. No warranties are expressed or implied that cover damage caused by what is considered normal use, or cover or imply how long any model cars' components or electronic components will last before requiring replacement.

Due to the high performance level of this model car you will need to periodically maintain and replace consumable components. Any and all warranty coverage will not cover replacement of any part or component damaged by neglect, abuse, or improper or unreasonable use. This includes but is not limited to damage from crashing, chemical and/or water damage, excessive moisture, improper or no maintenance, or user modifications

which compromise the integrity of components. Warranty will not cover components that are considered consumable on RC vehicles. XRAY DOES NOT pay nor refund shipping on any component sent to XRAY or its distributors for warranty. XRAY reserves the right to make the final determination of the warranty status of any component or part.

### **Limitations of Liability**

XRAY makes no other warranties expressed or implied. XRAY shall not be liable for any loss, injury or damages, whether direct, indirect, special, incidental, or consequential, arising from the use, misuse, or abuse of this product and/or any product or accessory required to operate this product. In no case shall XRAY's liability exceed the monetary value of this product.

**Take adequate safety precautions prior to operating this model. You are responsible for this model's assembly and safe operation.**

**Disregard of the any of the above cautions may lead to accidents, personal injury, or property damage. XRAY MODEL RACING CARS assumes no responsibility for any injury, damage, or misuse of this product during assembly or operation, nor any additions that may arise from the use of this product. All rights reserved.**

## **QUALITY CERTIFICATE**

XRAY MODEL RACING CARS uses only the highest quality materials, the best compounds for molded parts and the most sophisticated manufacturing processes of TQM (Total Quality Management). We guarantee that all parts of a newly-purchased kit are manufactured with the highest regard to quality. However, due to the many factors inherent in model racecar competition, we cannot guarantee any parts once you start racing the car. Products which

have been worn out, abused, neglected or improperly operated will not be covered under warranty.

We wish you enjoyment of this high-quality and high-performance RC car and wish you best success on the track!

**In line with our policy of continuous product development, the exact specifications of the kit may vary. In the unlikely event of any problems with your new kit, you should contact the model shop where you purchased it, quoting the part number. We do reserve all rights to change any specification without prior notice. All rights reserved.**

# TOOLS REQUIRED



Power Tool Tip Allen 2.0 x 90mm  
(HUDY #112071)



Power Tool Tip Allen 2.5 x 90mm  
(HUDY #112571)



Turnbuckle Wrench 3mm  
(HUDY #181030)



Turnbuckle Wrench 4mm  
(HUDY #181040)

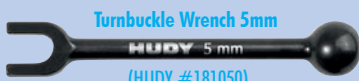

Turnbuckle Wrench 5mm  
(HUDY #181050)



Special Tool for turnbuckles, nuts (HUDY #181090)



Wheel Nut Tool 17mm (HUDY #107570)  
Flywheel/Wheel Nut Multi-Tool (HUDY #182016)



Cross Wrench Glowplug  
(HUDY #107581)  
• 10mm Socket  
• 8mm Socket  
• 5mm Hex



Ball Joint Wrench  
(HUDY #181110)



Pocket Hobby Knife (HUDY #188981)

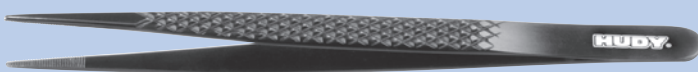

HUDY Tweezers Straight (HUDY #188970)



HUDY Tweezers Curved (HUDY #188971)



Allen 1.5mm (#111545 - HUDY EXCLUSIVE Limited Edition)



Allen 2.0mm (#112045 - HUDY EXCLUSIVE Limited Edition)



Ball Allen 2.0mm (#132045 - HUDY EXCLUSIVE Limited Edition)



Allen 2.5mm (#112545 - HUDY EXCLUSIVE Limited Edition)

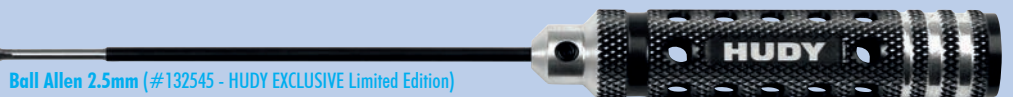

Ball Allen 2.5mm (#132545 - HUDY EXCLUSIVE Limited Edition)



Allen 3.0mm (#113045 - HUDY EXCLUSIVE Limited Edition)



Arm Reamer 3.0mm (#107643 - HUDY EXCLUSIVE Limited Edition)



Arm Reamer 4.0mm (#107644 - HUDY EXCLUSIVE Limited Edition)



Socket 5.0mm (#175035 - HUDY EXCLUSIVE Limited Edition)



Socket 5.5mm (#175535 - HUDY EXCLUSIVE Limited Edition)



Caster Clip Remover (#107612 - HUDY EXCLUSIVE Limited Edition)

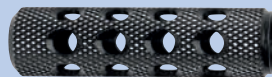

Reamer (#107602 - HUDY EXCLUSIVE Limited Edition)



Blade Hobby Knife with Alu Handle (HUDY #188980)













Professional Multi-Tool  
(HUDY #183011)



Scissors (HUDY #188990)

## EQUIPMENT INCLUDED



|   |   |   |   |   |
|---|---|---|---|---|
| <p>550cSt (#106356)<br/>HUDY Premium Silicone Oils</p>  <p>550cSt</p>  <p>OIL</p> | <p>600cSt (#106361)<br/>HUDY Premium Silicone Oils</p>  <p>600cSt</p>  <p>OIL</p> | <p>3.000cSt (#106431)<br/>HUDY Premium Silicone Oils</p>  <p>3.000cSt</p>  <p>OIL</p> | <p>7.000cSt (#106471)<br/>HUDY Premium Silicone Oils</p>  <p>7.000cSt</p>  <p>OIL</p> | <p>(HUDY #106210)<br/>Premium Graphite Grease</p>   <p>GR<br/>GRAPHITE<br/>GREASE</p> |
|---|---|---|---|---|

At the beginning of each section is an exploded view of the parts to be assembled. There is also a list of all the parts and part numbers that are related to the assembly of that section.

The part descriptions are color-coded to make it easier for you to identify the source of a part. Here are what the different colors mean:

- 351200 **STYLE A** - indicates parts that are included in the bag marked for the section.
- 351190 **STYLE B** - indicates parts that are included in the box.
- 355000 **STYLE C** - indicates parts that are already assembled from previous steps.
- 350910 **STYLE D** - indicates parts that are optional.

## EQUIPMENT REQUIRED

|  |   |  |   |
|--|---|--|---|
| <p>Transmitter</p>                                        | <p>Receiver</p>    | <p>Speed Controller</p>    | <p>Steering Servo</p>    |
| <p>Battery Charger</p>                                    | <p>Electric Motor</p>    | <p>Pinion Gear<br/> <span style="color: blue;">#355712-18 (STEEL NARROW 5mm)</span><br/> <span style="color: blue;">#294313-18 (STEEL WIDE 7mm OPTION)</span><br/> <span style="color: blue;">#355819-24 (ALU WIDE 7mm OPTION)</span></p>  | <p>Lexan™ Paint</p>    |
| <p>Alu RC Fan 40mm<br/>(HUDY #293104)</p>                 | <p>Double-sided Tape<br/>(HUDY #107875)</p>    | <p>Tires &amp; Wheels</p>    | <p>CA glue</p>   <p>CA<br/>GLUE</p> |
| <p>LiPo Battery Saddle Pack<br/>Short &amp; Mid-pack</p>  | <p>Bearing Oil<br/>(HUDY #106230)</p>   <p>OIL</p> | <p>Threadlock</p>   <p>TL<br/>THREAD<br/>LOCK</p>  |   |

# MAINTENANCE

## SHOCK MAINTENANCE

Correct refilling and bleeding are critical for consistent shock performance. When built correctly, frequent rebuilding is NOT required. Regularly inspect and replace damaged rubber bladders, O-rings, bent shock shafts, and worn or loose ball joints.

- Before each race, check shocks for air inside. Remove the spring, compress the shock fully, and listen for any whistling or squishy sound. If air is present, refill and bleed the shock.
- For high-level competition, refill and bleed shocks before major events.
- When building or pairing shocks, ensure they are equal in length & adjust lower ball joints as required.
- Inspect shocks after each race and replace oil as needed.

## SUSPENSION & DRIVETRAIN MAINTENANCE

Check suspension for free movement with the shocks removed during building and operation, especially after running or crashes. The suspension must move freely under its own weight. If it DOES NOT move freely, use the appropriate HUDY Arm Reamer to clean and resize the suspension arm holes, or replace any bent components.

Check suspension free movement with the car ready to run. Always verify ride height. Press the car down and release it, then lift it up and release it. If the suspension is stuck up or down, common causes include dirty or bent suspension pivot pins, bent shock shafts, pivot balls set too tight in the steering blocks, or dirty/worn pivot balls. Clean out or replace damaged/worn parts as necessary.

Check the drivetrain for free movement. There must be no locking, binding, or blocking during

rotation. With the motor/engine dismounted to eliminate drag, spin the wheels by hand and ensure smooth, free rolling. If the drivetrain does not roll freely, inspect all bearings and gears and replace worn or damaged parts as necessary.

Regularly inspect and replace the pins connecting the center driveshafts to the pinion gears, as well as the pins connecting wheel drive shafts to the wheel axles.

Pivot balls and ball joints will wear naturally and over time will develop minor play. If there is excess play, the pivot balls and ball joints should be replaced.

If the car is run in wet conditions, apply WD-40® on all drivetrain parts before the run. After the run, clean and dry the parts again.

## DRIVE SHAFT PIN SERVICING

Regularly check the drive shaft pins (both suspensions and center) and if they show any wear they must be immediately replaced by new pins. Inspect the pins after every 3 hours of runtime. If the car is run with worn out pins, excessive wear on the diff outrives will result. The **106000 HUDY Drive Pin Replacement Tool (for 3mm Pins)** is a compact, rugged multi-use tool set for replacing 3mm drive pins in drive shafts. Use the **HUDY replacement drive shaft pins 3x14 (#106050)**.



DO NOT use drive shafts when the pins are worn.

Press out the worn pins.

Press in new pins and regularly inspect for wear.



For easy drive pin replacements use **#106000 HUDY Drive Pin Replacement Tool**.



To replace the worn pins use only **premium HUDY drive pins #106050**.

## BEARING MAINTENANCE

Ball bearings must be properly maintained to ensure smooth drivetrain operation and long service life. New bearings are factory-greased for durability and may initially feel less free; this is normal.

- Clean and service bearings every 3–4 weeks or before major races.
- Check bearings for smooth operation. Replace any bearing with noise, vibration, or drag.
- Use only motor cleaners that leave no residue.
- Lightly oil bearings after cleaning. Short spin time when hand-tested is normal.
- When running in dirty conditions, it is recommended to use bearing grease after cleaning.

## CLUTCH BEARINGS

Regularly check the clutch bearings for smooth operation. Replace the bearings immediately if any wear, noise, or drag is detected.

## TECH TIPS

### TIP FRONT & REAR DIFF GEAR MESH ADJUSTMENT

If there is too much or too little diff side play, this may create non-optimal gear mesh between the diff gear and the pinion drive gear. This is easily resolved by inserting 1 or 2 of the included thin shims behind a diff outrive ball-bearing, depending on how much play there is.

THE LOCATION OF THE SHIM(S) DEPENDS ON WHETHER YOU ARE TRYING TO CLOSE OR OPEN THE GAP:

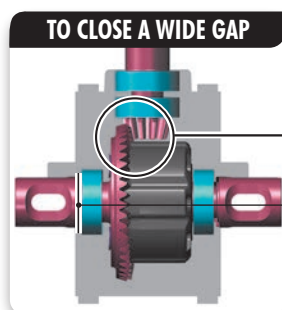

#### CLOSE A WIDE GAP



To CLOSE a wide gap: add 1 or 2 shims against diff spur gear

WASHER #962131 S 13 x 16 x 0.1 mm (10)  
#962130 S 13 x 16 x 0.2 mm (10)

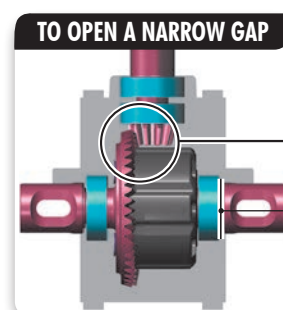

#### OPEN A NARROW GAP



To OPEN a narrow gap: add 1 or 2 shims on the other side of the diff, away from spur gear

WASHER #962131 S 13x16x0.1mm (10)  
#962130 S 13x16x0.2mm (10)

**CHECK GEAR MESH AND DIFF PLAY ONLY AFTER THE ENTIRE GEARBOX IS MOUNTED TOGETHER WITH THE SUSPENSION HOLDERS ON THE CHASSIS. ALL PARTS ARE DESIGNED TO HAVE CERTAIN PLAY AND IT IS ALL DESIGNED BY PURPOSE.**

# HUDY PREMIUM SILICONE OILS



| HUDY PREMIUM SILICONE OILS |                   |          |         |                    |        |
|----------------------------|-------------------|----------|---------|--------------------|--------|
| FOR GEAR DIFFERENTIAL      |                   |          |         |                    |        |
| #106411                    | 1.000cSt - 100ml  | OPTION   | #106513 | 12.000cSt - 100ml  | OPTION |
| #106421                    | 2.000cSt - 100ml  | OPTION   | #106516 | 15.000cSt - 100ml  | OPTION |
| #106431                    | 3.000cSt - 100ml  | INCLUDED | #106518 | 17.000cSt - 100ml  | OPTION |
| #106441                    | 4.000cSt - 100ml  | OPTION   | #106521 | 20.000cSt - 100ml  | OPTION |
| #106451                    | 5.000cSt - 100ml  | OPTION   | #106531 | 30.000cSt - 100ml  | OPTION |
| #106461                    | 6.000cSt - 100ml  | OPTION   | #106541 | 40.000cSt - 100ml  | OPTION |
| #106471                    | 7.000cSt - 100ml  | INCLUDED | #106551 | 50.000cSt - 100ml  | OPTION |
| #106481                    | 8.000cSt - 100ml  | OPTION   | #106561 | 60.000cSt - 100ml  | OPTION |
| #106491                    | 9.000cSt - 100ml  | OPTION   | #106587 | 80.000cSt - 100ml  | OPTION |
| #106511                    | 10.000cSt - 100ml | OPTION   | #106611 | 100.000cSt - 100ml | OPTION |
| #106493                    | 11.000cSt - 100ml | OPTION   |         |                    |        |

| HUDY PREMIUM SILICONE OILS |                |        |         |                |          |
|----------------------------|----------------|--------|---------|----------------|----------|
| FOR SHOCK ABSORBERS        |                |        |         |                |          |
| #106326                    | 250cSt - 100ml | OPTION | #106356 | 550cSt - 100ml | INCLUDED |
| #106331                    | 300cSt - 100ml | OPTION | #106358 | 575cSt - 100ml | OPTION   |
| #106336                    | 350cSt - 100ml | OPTION | #106361 | 600cSt - 100ml | INCLUDED |
| #106338                    | 375cSt - 100ml | OPTION | #106363 | 625cSt - 100ml | OPTION   |
| #106341                    | 400cSt - 100ml | OPTION | #106366 | 650cSt - 100ml | OPTION   |
| #106343                    | 425cSt - 100ml | OPTION | #106368 | 675cSt - 100ml | OPTION   |
| #106346                    | 450cSt - 100ml | OPTION | #106371 | 700cSt - 100ml | OPTION   |
| #106348                    | 475cSt - 100ml | OPTION | #106376 | 750cSt - 100ml | OPTION   |
| #106351                    | 500cSt - 100ml | OPTION | #106381 | 800cSt - 100ml | OPTION   |
| #106353                    | 525cSt - 100ml | OPTION | #106391 | 900cSt - 100ml | OPTION   |



## TIP

All ball-bearings are factory pre-oiled or pre-greased. The bearings are all packaged in BAG 00.9.

For pre-oiled ball-bearings, use:

#106230 HUDY Bearing Oil.

For pre-greased ball-bearings, use one of these bearing greases:

#106220 - HUDY Bearing Grease - suggested for extremely dusty track conditions.

#106221 - HUDY Bearing Grease "Blue" - suggested for medium dusty track conditions.

#106222 - HUDY Bearing Grease "Red" - suggested for low dusty track conditions.

Replace any bearings that develop a "gritty" feeling to prevent inefficiency and avoid failures.

Make sure to use only original XRAY ball-bearings, which all have specific tolerances, axial and radial play, and are all individually selected. Using 3rd party ball-bearings may result in bearing failures and damage to other parts.

# 1. FRONT & REAR DIFFERENTIALS



## XRAY BALL-BEARINGS

| OPTION | Part #  | Size   | Lubricant | Material | Status   |
|--------|---------|--------|-----------|----------|----------|
|        | #930816 | 8x16x5 | GREASE    | STEEL    | OPTION   |
|        | #930817 | 8x16x5 | OIL       | STEEL    | OPTION   |
|        | #940816 | 8x16x5 | GREASE    | RUBBER   | INCLUDED |
|        | #940817 | 8x16x5 | OIL       | RUBBER   | OPTION   |



**00.9**  
BAG



In the kit there is a BAG 00.9 with pre-greased ball-bearings or with pre-oiled ball-bearings. Follow tech tip on page 7.

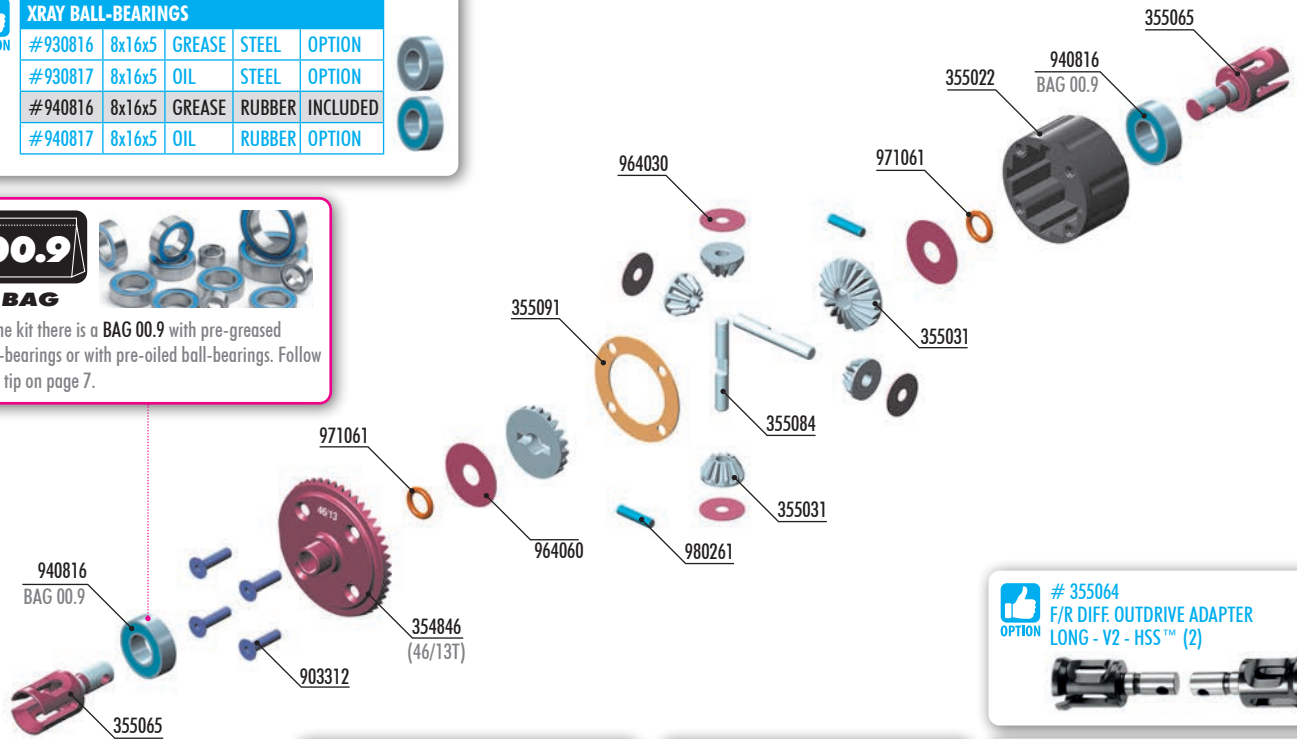

**#355022-G**  
DIFFERENTIAL CASE  
V2 - GRAPHITE



**#355085**  
HEAT RESISTANT ALU DIFF PIN &  
INSERTS - 2G CONFIG. F/R (2+4)



**#355064**  
F/R DIFF OUTDRIVE ADAPTER  
LONG - V2 - HSS™ (2)



**#355086**  
HEAT-RESISTANT F/R ALU  
DIFF PINS + INSERTS (SET)

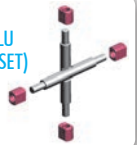

## BAGS

**01.1**

2x

- 354846 F/R DIFF LARGE BEVEL GEAR 46T - MATCHED FOR 13T PINION GEAR
- 355006 DIFFERENTIAL 46T - MATCHED FOR 13T PINION GEAR - SET
- 355022 DIFFERENTIAL CASE - V2
- 355031 STEEL DIFF BEVEL & SATELLITE GEARS - V2 (2+4)
- 355065 DIFF OUTDRIVE ADAPTER - V2 - HUDY SPRING STEEL™ (2)
- 355084 F/R DIFF PIN (2)
- 355091 F/R DIFF GASKET (4)

- 903312 HEX SCREW SFH M3x12 (10)
- 940816 BALL-BEARING 8x16x5 RUBBER SEALED - GREASE (2)
- 964030 WASHER S 3.5x12x0.2 (10)
- 964060 WASHER S 6x18x0.2 (10)
- 971061 SILICONE O-RING 6x1.55 (10)
- 980261 PIN 2.5x11.5 (10)

Numbers in parentheses ( ) refer to quantities when purchased separately.

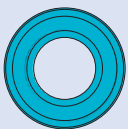

2x 940816  
BB 8x16x5



2x 964060  
S 6x18x0.2



2x 971061  
O 6x1.55

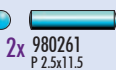

2x 980261  
P 2.5x11.5

**SET-UP  
BOOK**

DIFFERENTIAL GEARS

2x

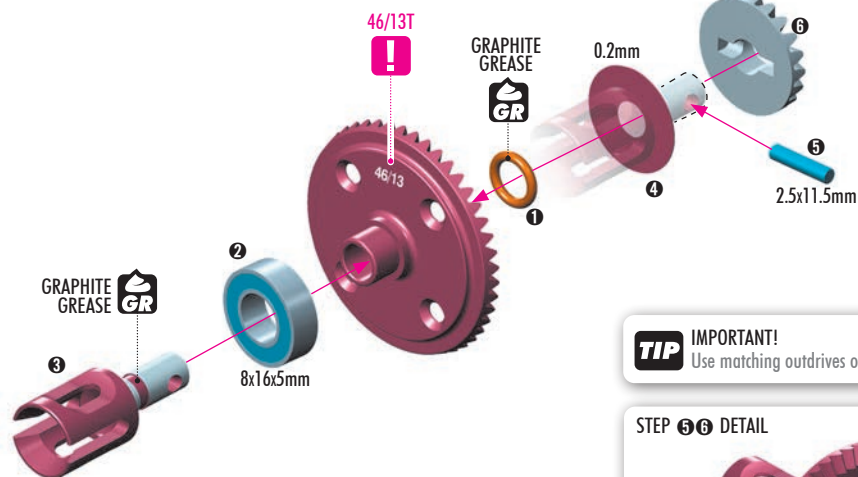

**TIP** IMPORTANT!  
Use matching outdrives on left and right sides of a diff.

STEP 5 6 DETAIL

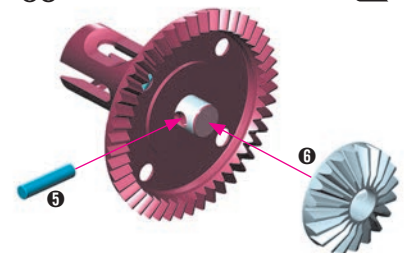

## XRAY BALL-BEARINGS

| OPTION | Part #  | Size   | Lubricant | Material | Status   |
|--------|---------|--------|-----------|----------|----------|
|        | #930816 | 8x16x5 | GREASE    | STEEL    | OPTION   |
|        | #930817 | 8x16x5 | OIL       | STEEL    | OPTION   |
|        | #940816 | 8x16x5 | GREASE    | RUBBER   | INCLUDED |
|        | #940817 | 8x16x5 | OIL       | RUBBER   | OPTION   |



# 1. FRONT & REAR DIFFERENTIALS



2x 940816  
BB 8x16x5

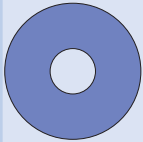

2x 964060  
S 6x18x0.2



2x 971061  
O 6x11.55



2x 980261  
P 2.5x11.5

2x

**TIP** IMPORTANT!  
Use matching outdrives on left and right sides of a diff.

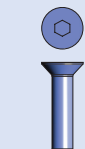
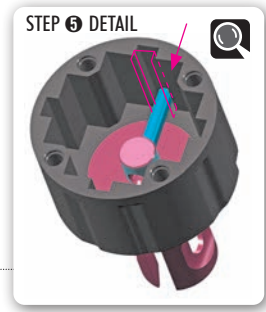
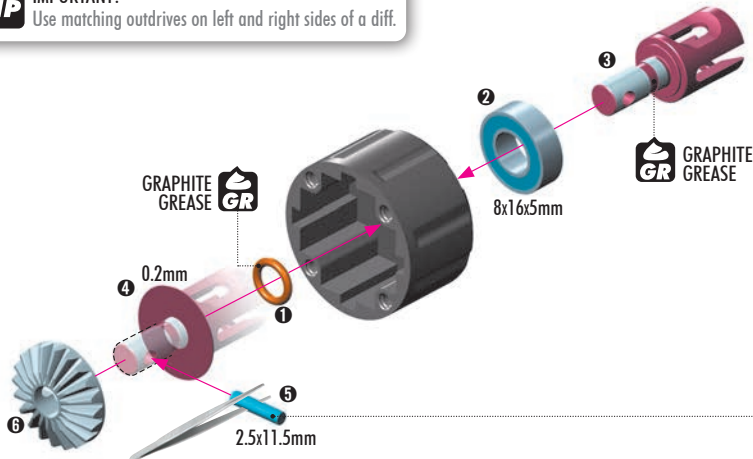

8x 903312  
SFH M3x12



8x 964030  
S 3.5x12x0.2

2x

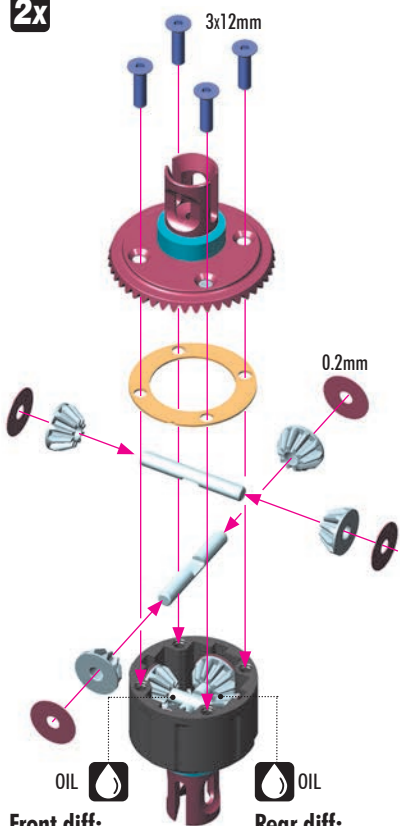

**Front diff:**  
Silicone oil **7.000cSt**  
Fill just above the satellite gears.

**Rear diff:**  
Silicone oil **3.000cSt**  
Fill just above the satellite gears.

## VERY IMPORTANT!

Use the following silicone oils included in the kit for INITIAL settings:  
FRONT diff: **7.000cSt** / REAR diff: **3.000cSt**

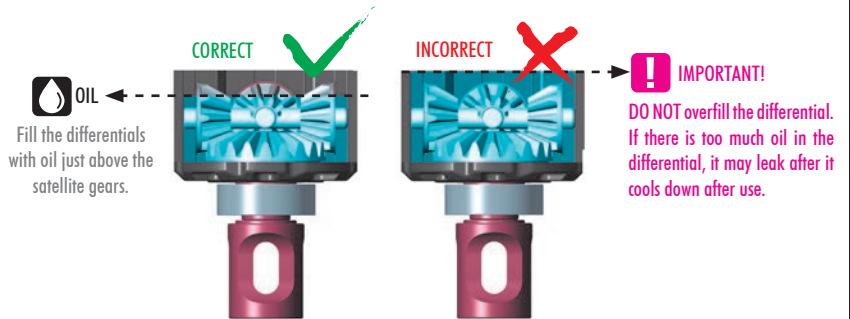

To ensure you have the same amount of oil from rebuild to rebuild, do the following:

#107865 HUDY Ultimate Digital Pocket Scale 300g ± 0.01g  
OPTION #107866 HUDY Professional Digital Pocket Scale 3000g/0.1g



1. Put the diff (without oil) on the scale and check the weight:  
- REAR DIFF approx. 39.30g  
- FRONT DIFF approx. 39.30g

2. Slowly pour oil into the diff and watch the weight.  
Add 2.60g of oil into the diff. The approximate weight of the diff+oil is approx. 41.90g

|            |                |          |
|------------|----------------|----------|
| REAR DIFF  | 39.30g + 2.60g | = 41.90g |
| FRONT DIFF | 39.30g + 2.60g | = 41.90g |

**SET-UP BOOK**  
DIFFERENTIAL OIL

Tighten the screws equally.



Finish tightening in this order:

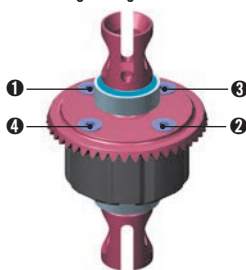

After assembly the differentials should have a length of 32.3~32.7 mm measured from the ends of the installed ball-bearings. If the differentials are longer, check that the gear is properly seated on the case and retighten the 4 screws while holding the crown gear.

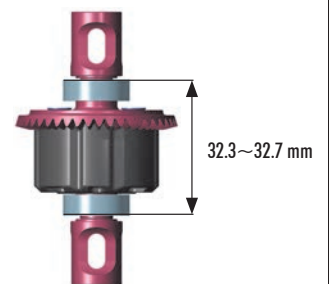

# 1. CENTER DIFFERENTIAL



## XRAY BALL-BEARINGS

| OPTION | Part #  | Size   | Lubricant | Material | Status   |
|--------|---------|--------|-----------|----------|----------|
|        | #930816 | 8x16x5 | GREASE    | STEEL    | OPTION   |
|        | #930817 | 8x16x5 | OIL       | STEEL    | OPTION   |
|        | #940816 | 8x16x5 | GREASE    | RUBBER   | INCLUDED |
|        | #940817 | 8x16x5 | OIL       | RUBBER   | OPTION   |

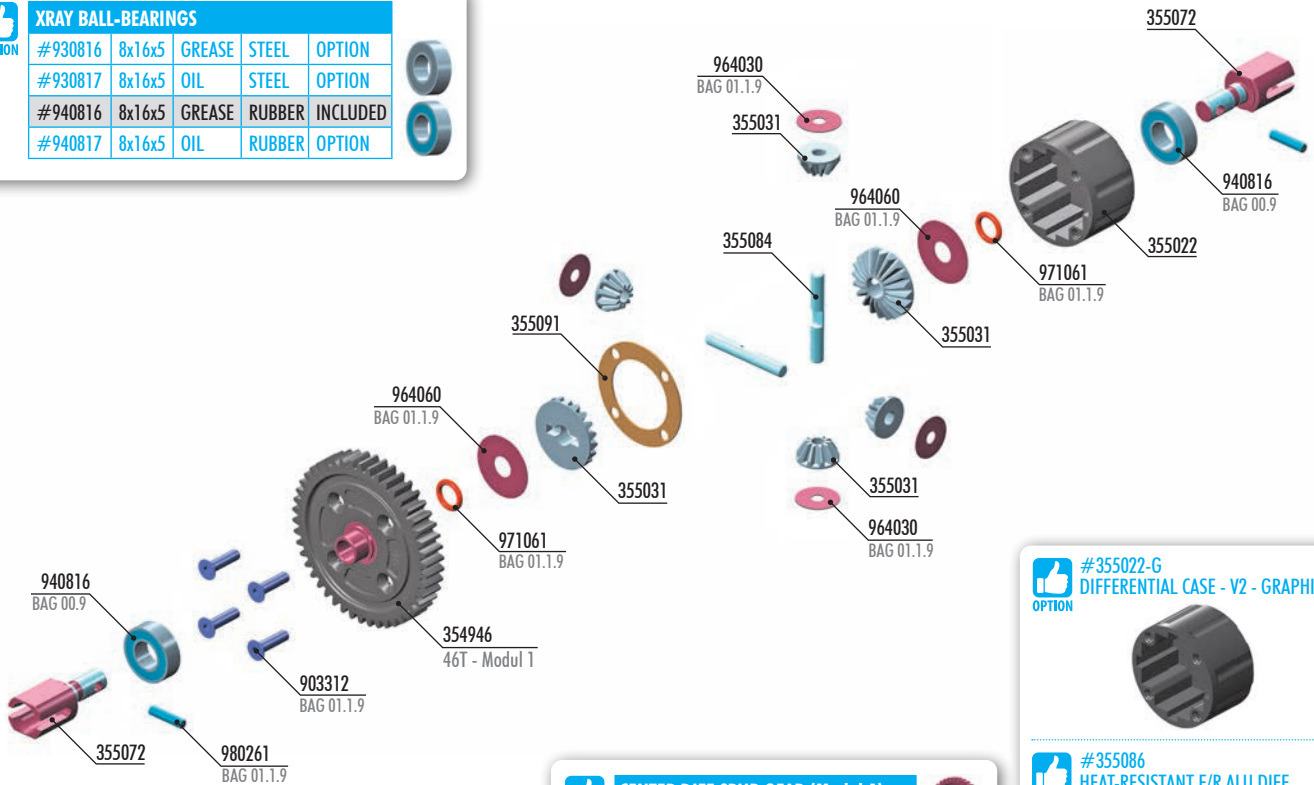
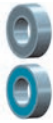

## CENTER DIFF SPUR GEAR (Modul 1)

| OPTION | Part #    | Teeth | Material  | Status   |
|--------|-----------|-------|-----------|----------|
|        | #355052   | 44T   | STEEL     | OPTION   |
|        | #355051   | 45T   | STEEL     | OPTION   |
|        | #355050   | 46T   | STEEL     | OPTION   |
|        | #354946   | 46T   | COMPOSITE | INCLUDED |
|        | #354946-G | 46T   | GRAPHITE  | OPTION   |



## #355022-G DIFFERENTIAL CASE - V2 - GRAPHITE

OPTION



## #355086 HEAT-RESISTANT F/R ALU DIFF PINS+ INSERTS (SET)

OPTION



### BAG

**01.3**

|        |   |        |  |
|--------|---|--------|--|
| 354946 | COMPOSITE CENTER DIFF SPUR GEAR WITH MOULDED-IN STEEL BUSHING 46T | 903312 | HEX SCREW SFH M3x12 (10)                       |
| 355014 | CENTER DIFFERENTIAL SMALL WITH COMPOSITE SPUR GEAR 46T - SET      | 940816 | BALL-BEARING 8x16x5 RUBBER SEALED - GREASE (2) |
| 355022 | DIFFERENTIAL CASE - V2  | 964030 | WASHER S 3.5x12x0.2 (10)                       |
| 355031 | STEEL DIFF BEVEL & SATELLITE GEARS - V2 (2+4)                     | 964060 | WASHER S 6x18x0.2 (10)                         |
| 355072 | LARGE CENTER DIFF OUTDRIVE ADAPTER - HUDY STEEL (2)               | 971061 | SILICONE O-RING 6x1.55 (10)                    |
| 355084 | DIFF PIN (2)  | 980261 | PIN 2.5x11.5 (10)                              |
| 355091 | DIFF GASKET (4)   |        |  |

Numbers in parentheses ( ) refer to quantities when purchased separately.



1x 940816  
BB 8x16x5



1x 964060  
S 6x18x0.2



1x 971061  
O 6x1.55



1x 980261  
P 2.5x11.5

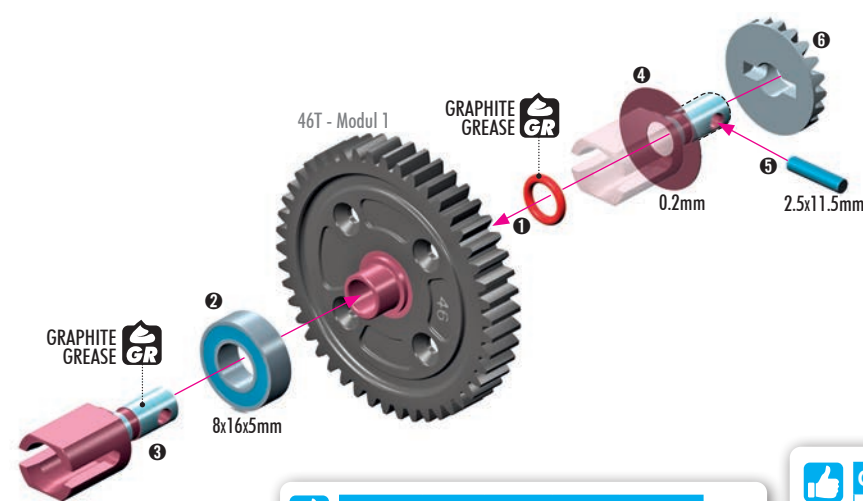

### STEP 5 & 6 DETAIL

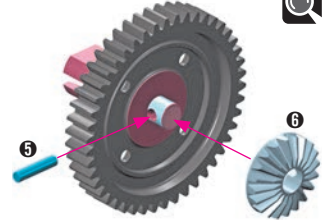

## XRAY BALL-BEARINGS

| OPTION | Part #  | Size   | Lubricant | Material | Status   |
|--------|---------|--------|-----------|----------|----------|
|        | #930816 | 8x16x5 | GREASE    | STEEL    | OPTION   |
|        | #930817 | 8x16x5 | OIL       | STEEL    | OPTION   |
|        | #940816 | 8x16x5 | GREASE    | RUBBER   | INCLUDED |
|        | #940817 | 8x16x5 | OIL       | RUBBER   | OPTION   |



## CENTER DIFF SPUR GEAR (Modul 1)

| OPTION | Part #    | Teeth | Material  | Status   |
|--------|-----------|-------|-----------|----------|
|        | #355052   | 44T   | STEEL     | OPTION   |
|        | #355051   | 45T   | STEEL     | OPTION   |
|        | #355050   | 46T   | STEEL     | OPTION   |
|        | #354946   | 46T   | COMPOSITE | INCLUDED |
|        | #354946-G | 46T   | GRAPHITE  | OPTION   |



# 1. CENTER DIFFERENTIAL



1x 940816  
BB 8x16x5



1x 964060  
S 6x18x0.2



1x 971061  
O 6x1.55

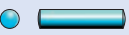

1x 980261  
P 2.5x11.5

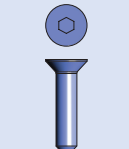
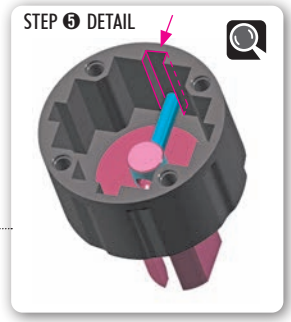
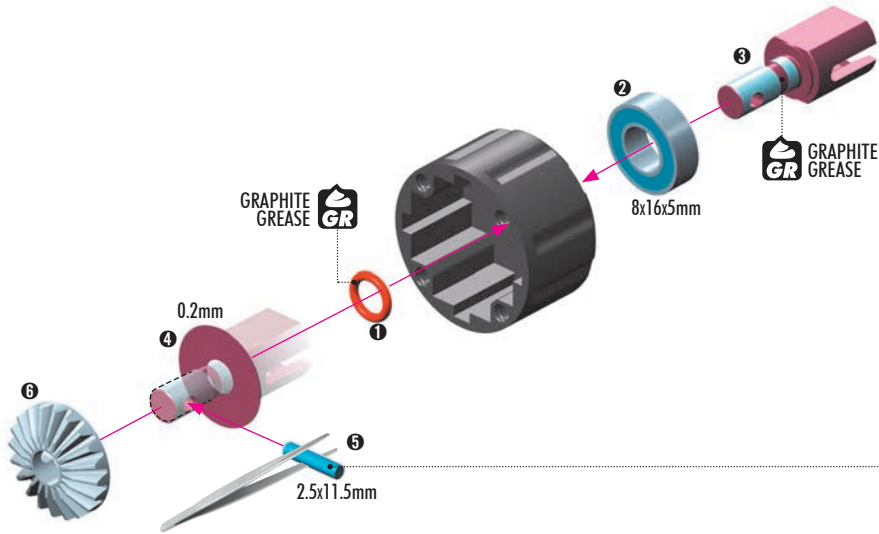

4x 903312  
SFH M3x12



4x 964030  
S 3.5x12x0.2

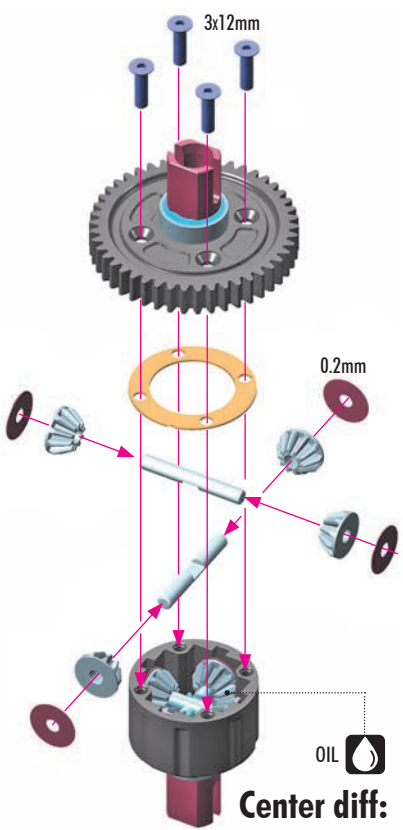

**Center diff:**  
Silicone oil 7.000cSt  
Fill to just above the satellite gears.

## VERY IMPORTANT!

Use the following silicone oil included in the kit for INITIAL setting:  
Center diff: 7.000cSt

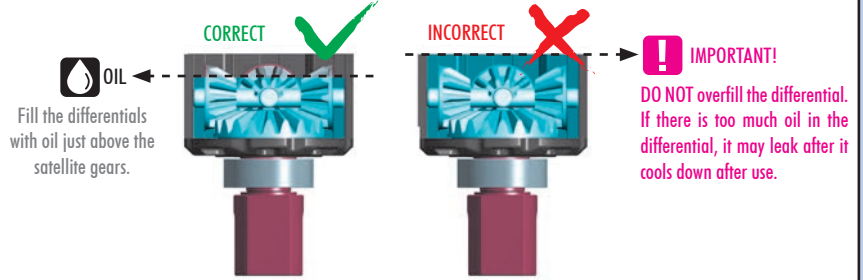

To ensure you have the same amount of oil from rebuild to rebuild, do the following:

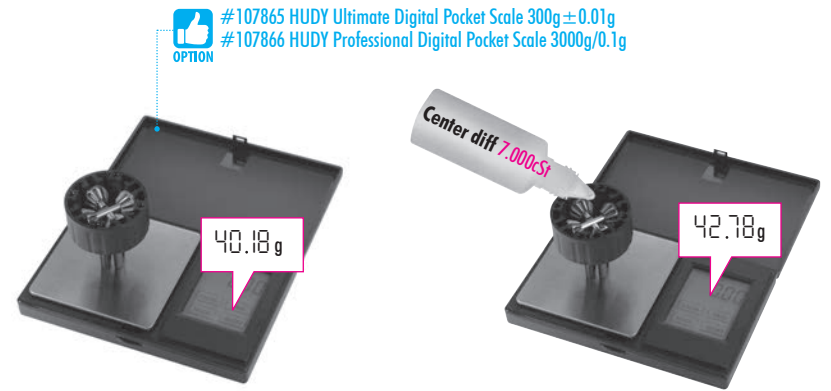

- Put the diff (without oil) on the scale and check the weight (approximately 40.18g).
- Slowly pour oil into the diff and watch the weight. Add 2.60g of oil into the diff. The approximate weight of the diff+oil is 42.78g.

**CENTER DIFF**  $40.18g + 2.60g = 42.78g$

**SET-UP BOOK**  
DIFFERENTIAL OIL

Tighten the screws equally.

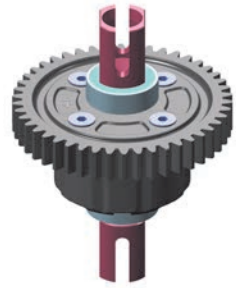

Finish tightening in this order:

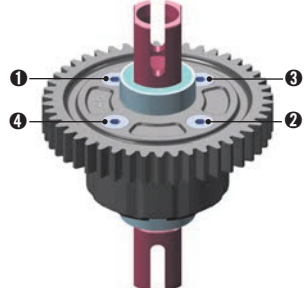

After assembly the differential should have a length of 32.3~32.7mm measured from the ends of the installed ball-bearings. If the differential is longer, check that the gear is properly seated on the case and retighten the 4 screws while holding the spur gear.

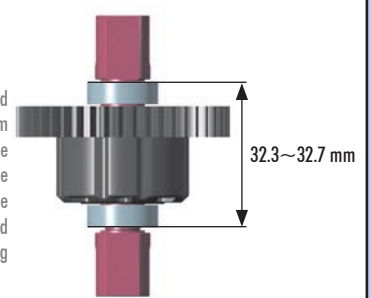

# FRONT & REAR DIFF ORIENTATION



The XRAY XB8E chassis offers two options for mounting the front and rear differentials. To increase traction we recommend using the INITIAL setting, which requires configuring the ESC to rotate in the opposite direction of the motor.

## ALTERNATIVE 1

✓ INITIAL SETTING

REAR  
DIFF ORIENTATION ✓ INITIAL SETTING



THIS CONFIGURATION GENERATES MORE TRACTION.

ESC Setup needs motor rotation = REV Reverse Motor Rotation only.

DIFF ORIENTATION ✓ INITIAL SETTING

FRONT

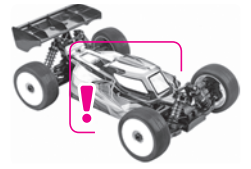

## ALTERNATIVE 2

REAR  
DIFF ORIENTATION



ESC Setup needs motor rotation = NOR - NORMAL Rotation.  
(DEFAULT ESC SETTING)

DIFF ORIENTATION FRONT

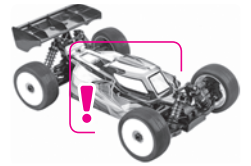

## 2. FRONT TRANSMISSION



### XRAY BALL-BEARINGS

| OPTION | #       | SIZE   | LUBRICATION | STEEL | STATUS   |
|--------|---------|--------|-------------|-------|----------|
|        | #930816 | 8x16x5 | GREASE      | STEEL | INCLUDED |
|        | #930817 | 8x16x5 | OIL         | STEEL | OPTION   |

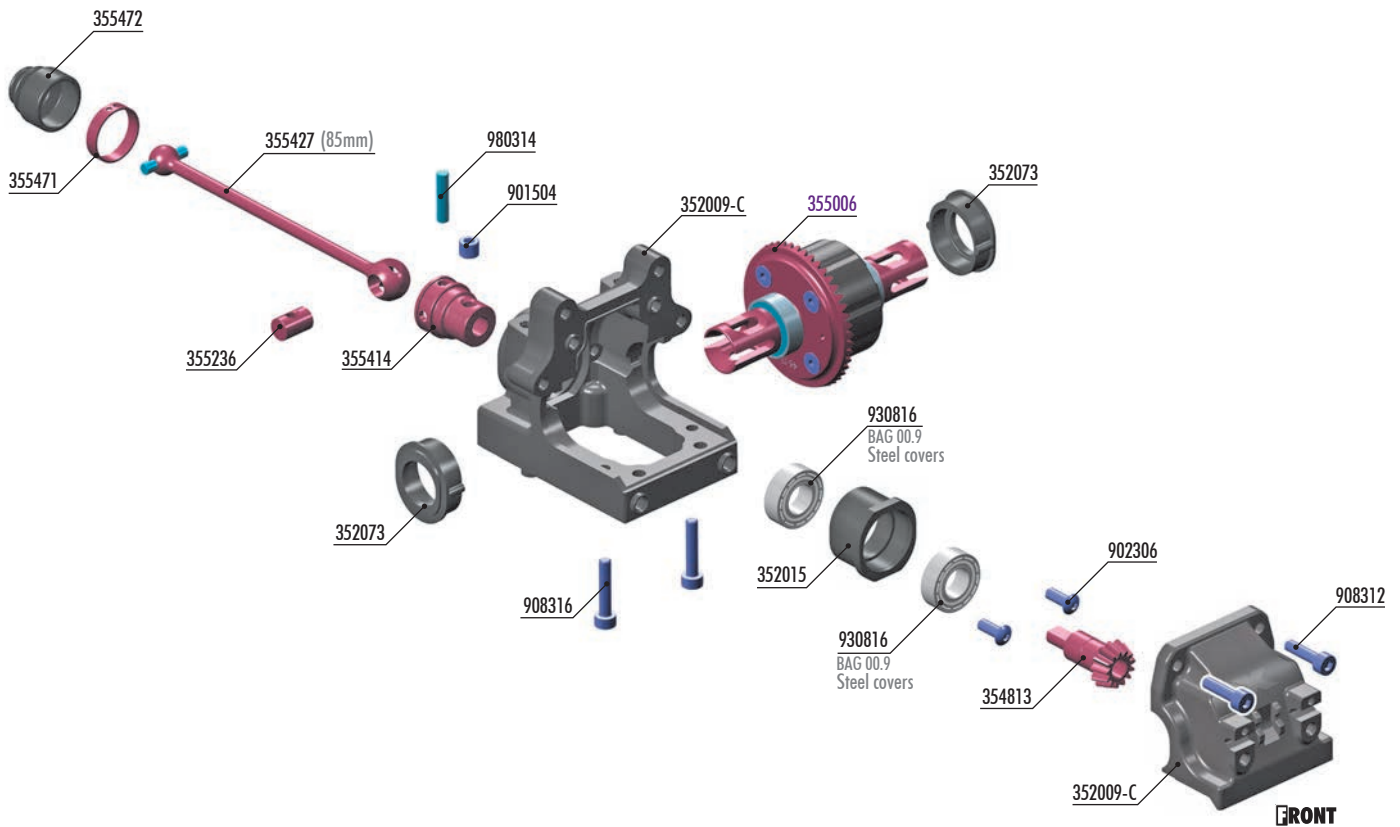

#354814 BEVEL DRIVE PINION GEAR 14T  
MATCHED FOR 46/13T LARGE BEVEL GEAR



#355415 CENTRAL DOGBONE SHAFT UNIVERSAL JOINT  
#355432 FRONT CENTRAL DOGBONE DRIVE SHAFT 85mm



BAG

02

352009-C SEMI-SPLIT DIFF BULKHEAD BLOCK SET FRONT/REAR FOR COLLAR  
352015 GEARBOX PINION HEIGHT INSERT (1+1)  
352073 GEARBOX DIFF HEIGHT INSERT (2+2)  
354813 BEVEL DRIVE PINION GEAR 13T - MATCHED FOR 46T LARGE BEVEL GEAR  
355236 CVD DRIVE SHAFT COUPLING - HUDY SPRING STEEL™  
355414 CENTRAL CVD SHAFT UNIVERSAL JOINT - HUDY SPRING STEEL™  
355427 FRONT CENTRAL CVD DRIVE SHAFT 85mm - HUDY SPRING STEEL™  
355471 DRIVE SHAFT LOCKING RING (2)  
355472 DRIVE SHAFT BOOT (2)

901504 HEX SCREW SB M5x4 (10)  
902306 HEX SCREW SH M3x6 (10)  
908312 HEX SCREW SOCKET HEAD CAP SCH M3x12 (10)  
908316 HEX SCREW SOCKET HEAD CAP SCH M3x16 (10)  
930816 BALL-BEARING 8x16x5 STEEL SEALED - GREASE (2)  
980314 PIN 3x14 (10)

355006 DIFFERENTIAL 46T - MATCHED FOR 13T PINION GEAR - SET

Numbers in parentheses ( ) refer to quantities when purchased separately.

## 2. FRONT TRANSMISSION

1x 980314  
P 3x14

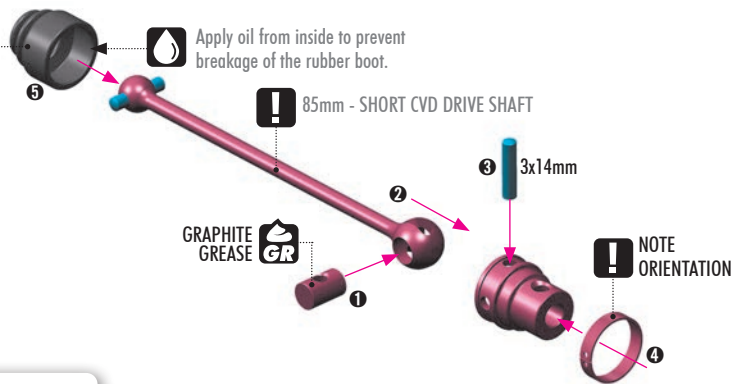
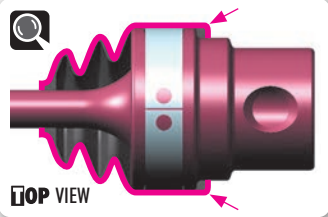

### STEP 4 DETAIL

The ring can be assembled by hand, but for easy disassembly we recommend using snap ring pliers.

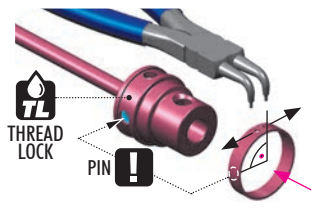

**BEFORE** inserting the dip on the central CVD shaft joint, apply a small amount of threadlock on the area where the clip goes.

**AFTER** inserting the clip on the central CVD shaft joint, turn the dip so that the slot is 90° from the pin. This will prevent the pin from opening the clip.

2x 902306  
SH M3x6

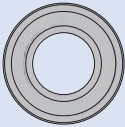

2x 930816  
BB 8x16x5  
(Steel covers)

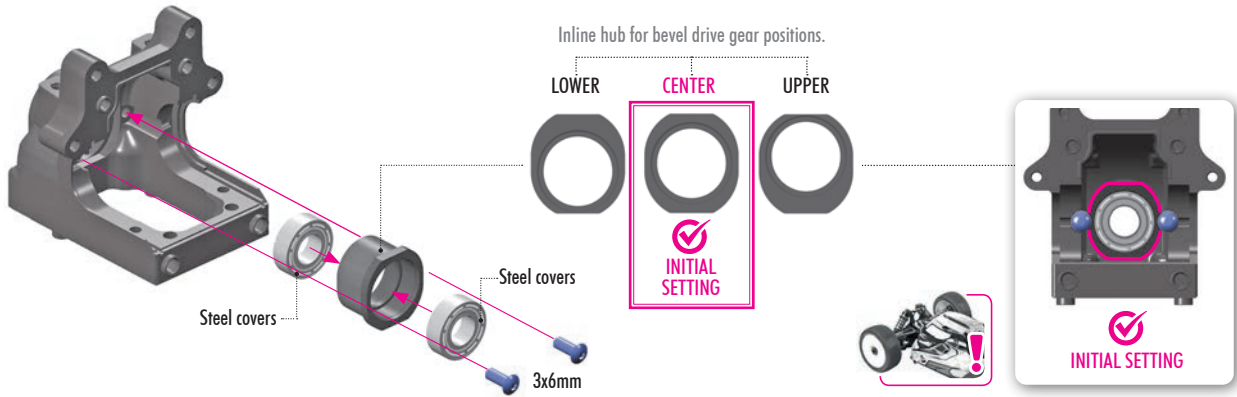

1x 901504  
SB M5x4

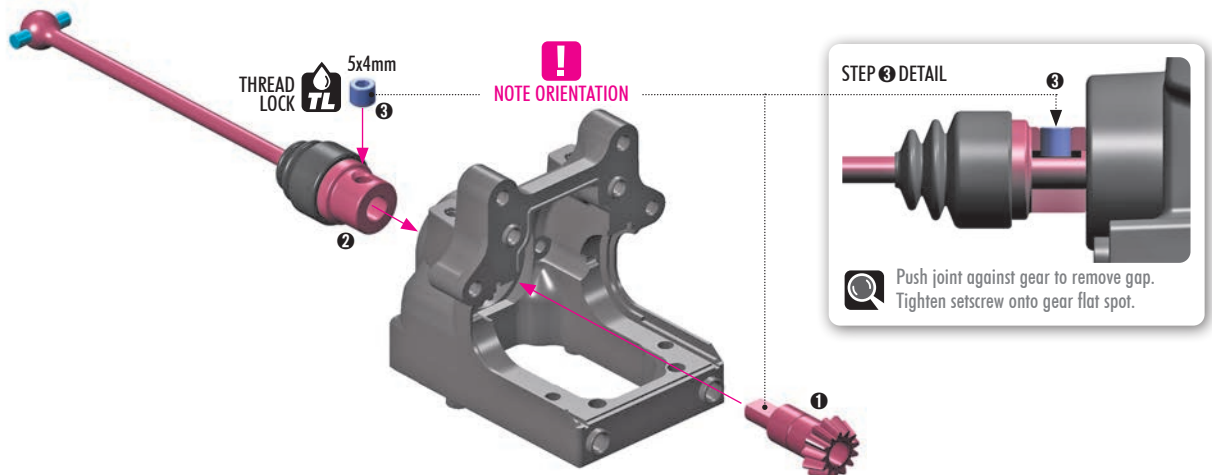

## 2. FRONT TRANSMISSION

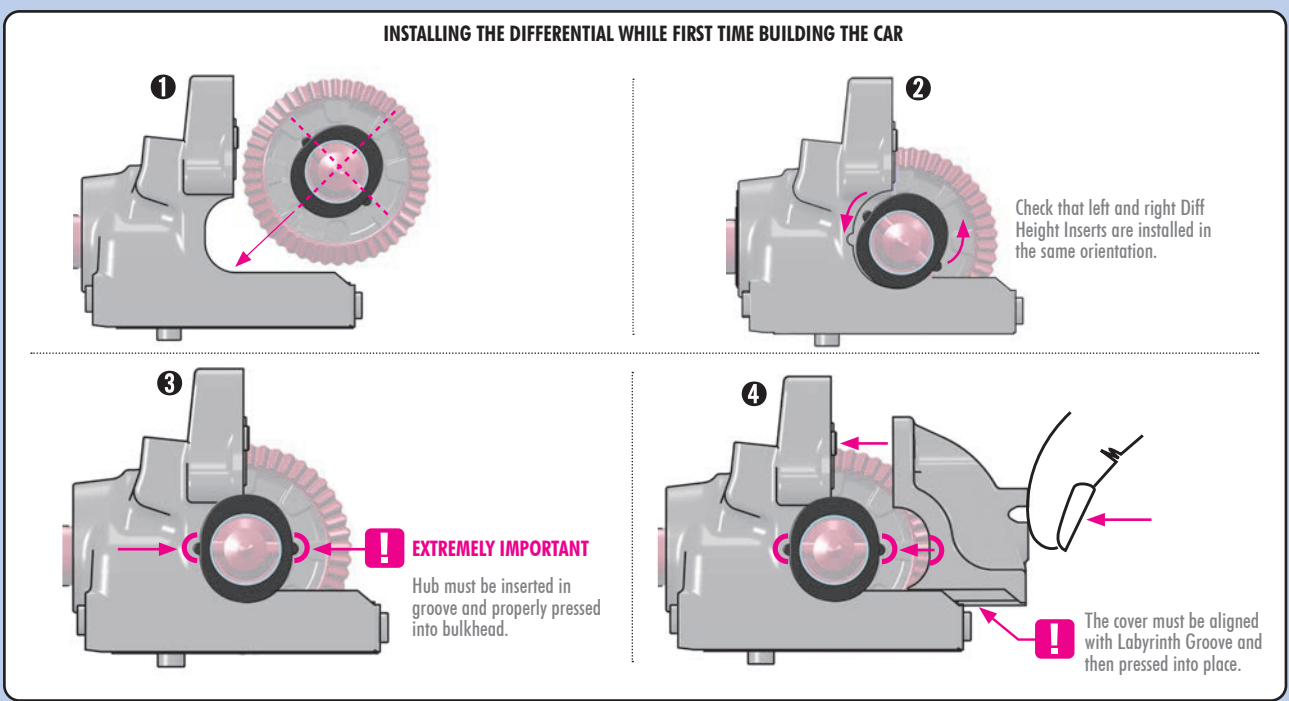
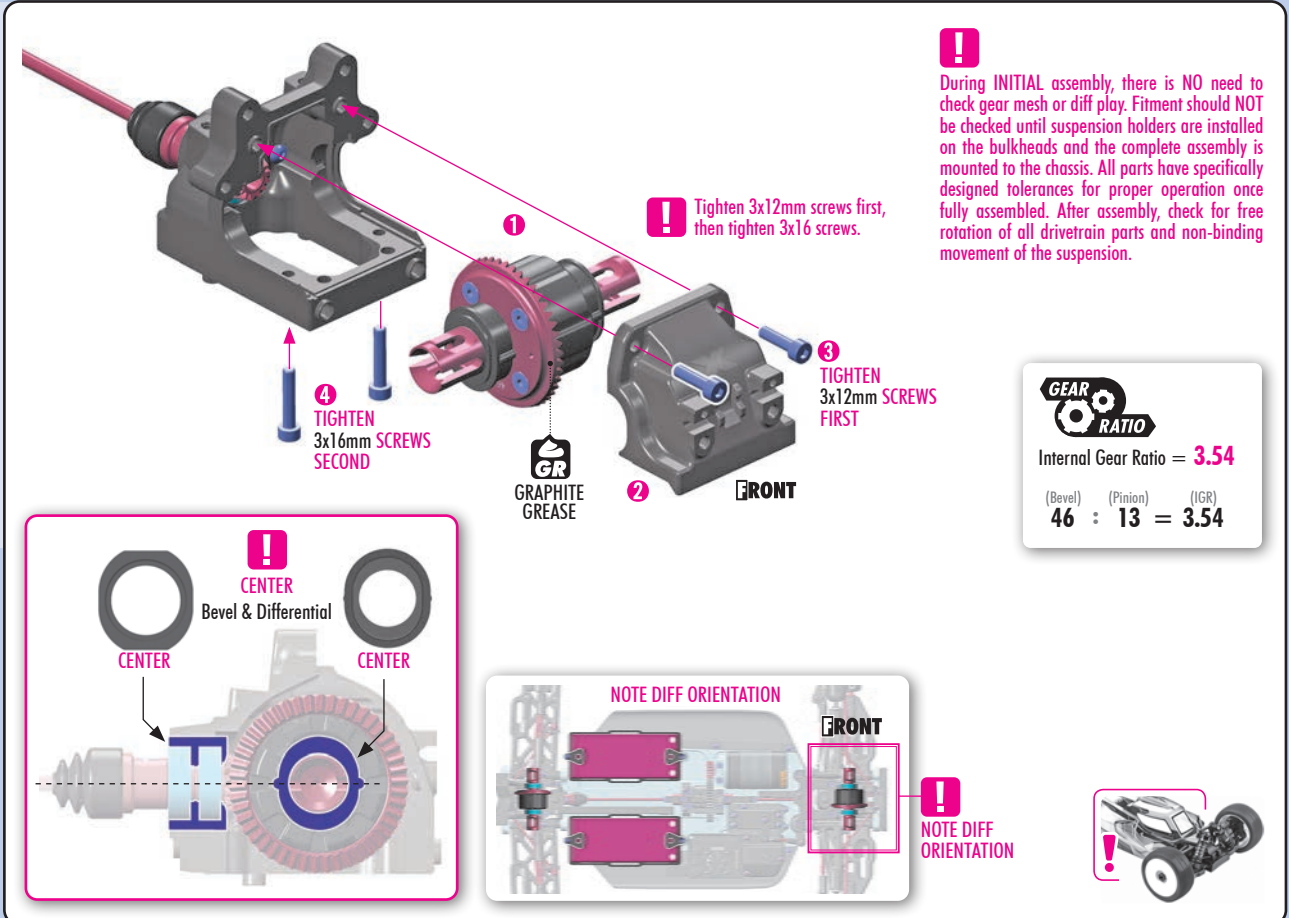
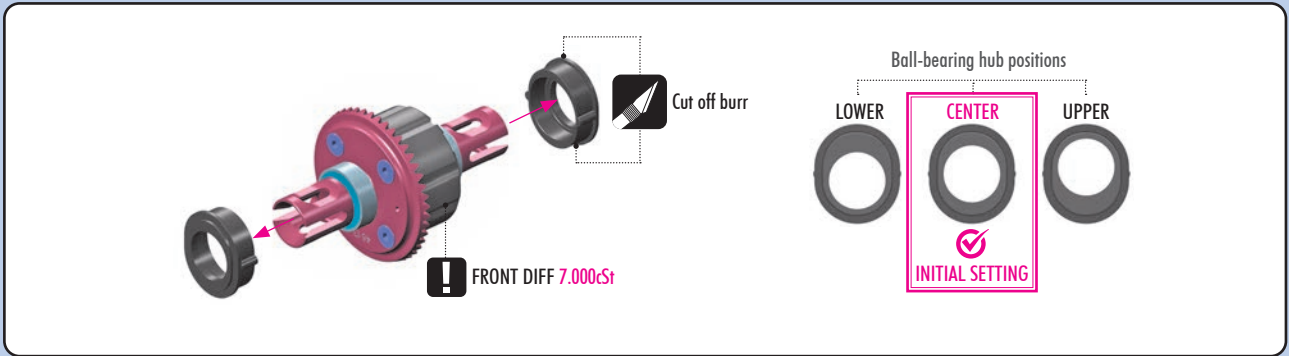

## 2. REAR TRANSMISSION

 **#354814 BEVEL DRIVE PINION GEAR 14T**  
**MATCHED FOR 46/13T LARGE BEVEL GEAR** 

 **XRAY BALL-BEARINGS**

|         |        |        |       |          |
|---------|--------|--------|-------|----------|
| #930816 | 8x16x5 | GREASE | STEEL | INCLUDED |
| #930817 | 8x16x5 | OIL    | STEEL | OPTION   |

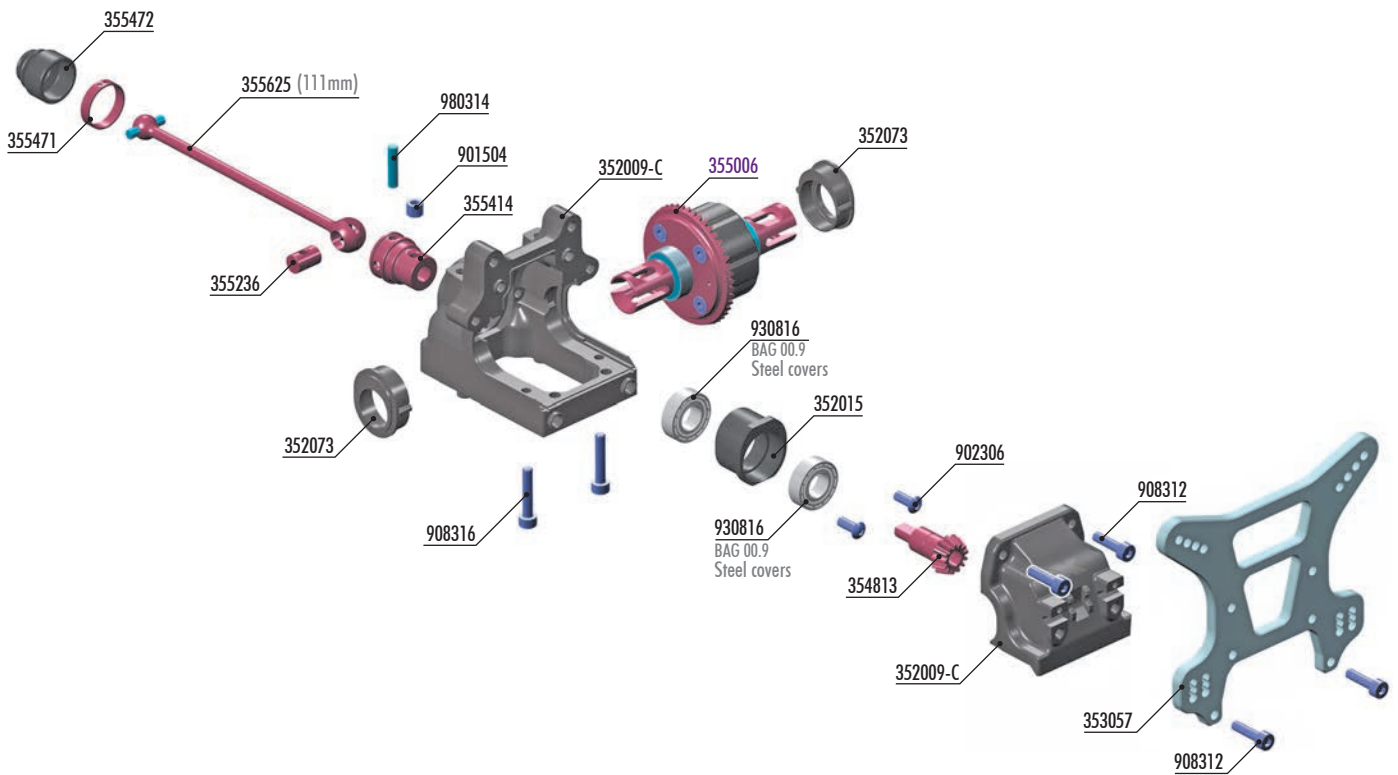
 **#355415 CENTRAL DOGBONE SHAFT UNIVERSAL JOINT - HUDY SPRING STEEL™ +**  
**#355635 REAR CENTRAL DOGBONE DRIVE SHAFT 111mm - HUDY SPRING STEEL™**



**BAG**  
**02**

352009-C SEMI-SPLIT DIFF BULKHEAD BLOCK SET FRONT/REAR FOR COLLAR  
 352015 GEARBOX PINION HEIGHT INSERT (1+1)  
 352073 GEARBOX DIFF HEIGHT INSERT (2+2)  
 353057 ALU REAR SHOCK TOWER FOR SEMI-SPLIT BULKHEAD - LOWER  
 354813 BEVEL DRIVE PINION GEAR 13T - MATCHED FOR 46T LARGE BEVEL GEAR  
 355236 CVD DRIVE SHAFT COUPLING - HUDY SPRING STEEL™  
 355414 CENTRAL CVD SHAFT UNIVERSAL JOINT - HUDY SPRING STEEL™  
 355471 DRIVE SHAFT LOCKING RING (2)  
 355472 DRIVE SHAFT BOOT (2)

355625 REAR CENTRAL CVD DRIVE SHAFT 111mm - HUDY SPRING STEEL™  
 901504 HEX SCREW SB M5x4 (10)  
 902306 HEX SCREW SH M3x6 (10)  
 908312 HEX SCREW SOCKET HEAD CAP SCH M3x12 (10)  
 908316 HEX SCREW SOCKET HEAD CAP SCH M3x16 (10)  
 930816 BALL-BEARING 8x16x5 STEEL SEALED - GREASE (2)  
 980314 PIN 3x14 (10)

355006 DIFFERENTIAL 46T - MATCHED FOR 13T PINION GEAR - SET

Numbers in parentheses ( ) refer to quantities when purchased separately.

## 2. REAR TRANSMISSION

1x 980314  
P 3x14

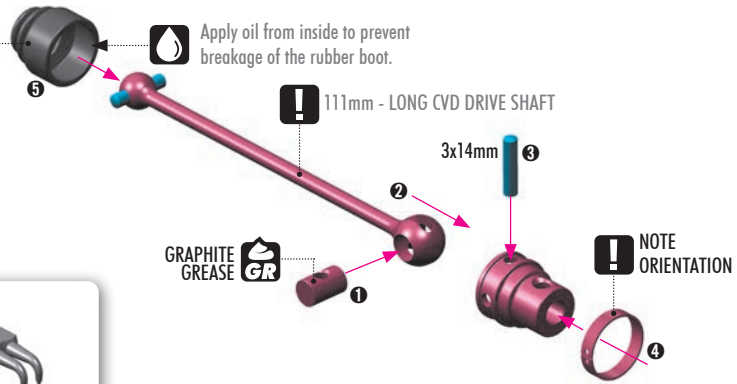
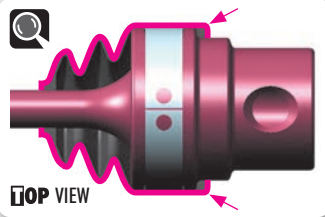

### STEP 4 DETAIL

The ring can be assembled by hand, but for easy disassembly we recommend using snap ring pliers.

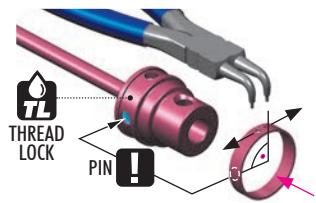

**BEFORE** inserting the clip on the central CVD shaft joint, apply a small amount of threadlock on the area where the clip goes.

**AFTER** inserting the clip on the central CVD shaft joint, turn the clip so that the slot is 90° from the pin. This will prevent the pin from opening the clip.

2x 902306  
SH M3x6

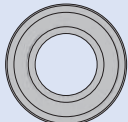

2x 930816  
BB 8x16x5  
(Steel covers)

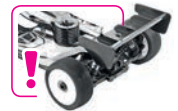
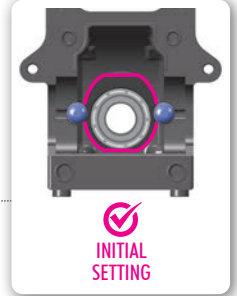
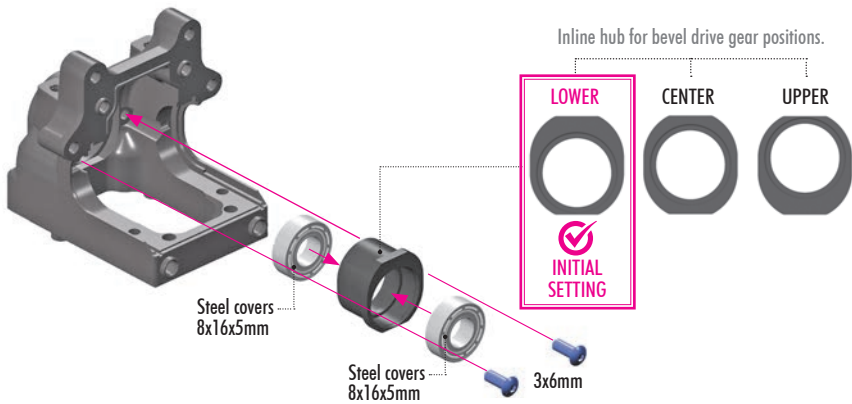

1x 901504  
SB M5x4

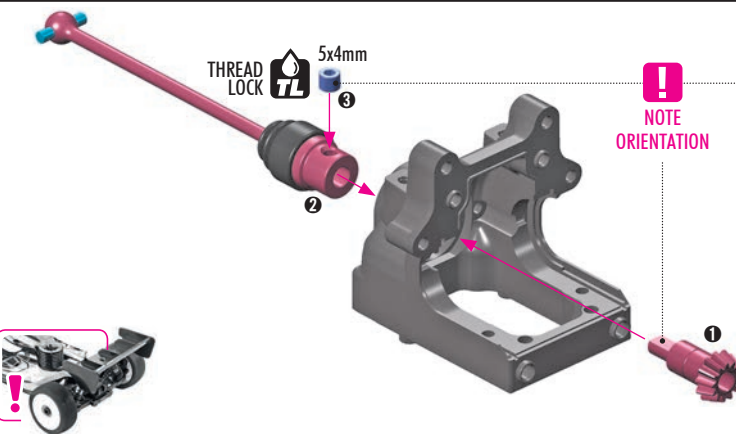

### STEP 5 DETAIL

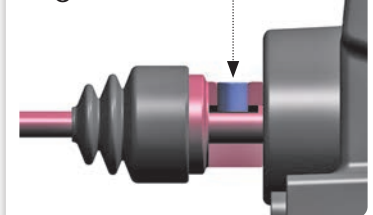

Push joint against gear to remove gap.  
Tighten setscrew onto gear flat spot.

### Ball-bearing hub positions

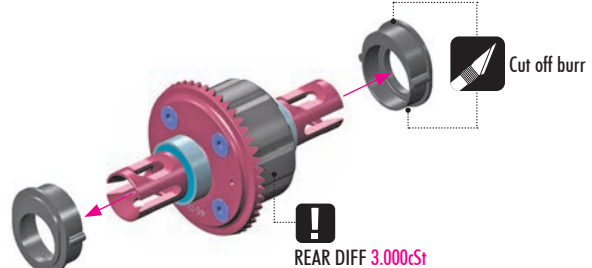
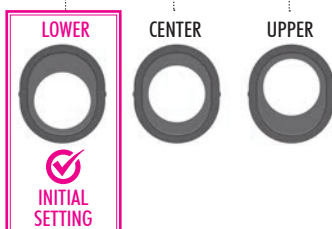

## 2. REAR TRANSMISSION

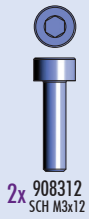

**!** Tighten 3x12mm screws first, then tighten 3x16 screws.

**!** During INITIAL assembly, there is NO need to check gear mesh or diff play. Fitment should NOT be checked until suspension holders are installed on the bulkheads and the complete assembly is mounted to the chassis. All parts have specifically designed tolerances for proper operation once fully assembled. After assembly, check for free rotation of all drivetrain parts and non-binding movement of the suspension.

**1** TIGHTEN 3x12mm SCREWS FIRST

**2** GRAPHITE GREASE GR

**3** TIGHTEN 3x16mm SCREWS SECOND

**4** TIGHTEN 3x16mm SCREWS SECOND

**!** LOWER Bevel & Differential

LOWER

NOTE DIFF ORIENTATION

**!** NOTE DIFF ORIENTATION

### INSTALLING THE DIFFERENTIAL WHILE FIRST TIME BUILDING THE CAR

**1**

**2** Check that left and right Diff Height Inserts are installed in the same orientation.

**3** **!** EXTREMELY IMPORTANT  
Hub must be inserted in groove and properly pressed into bulkhead.

**4** **!** The cover must be aligned with Labyrinth Groove and then pressed into place.

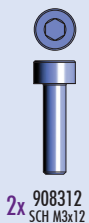

3x12mm

# 3. REAR SUSPENSION

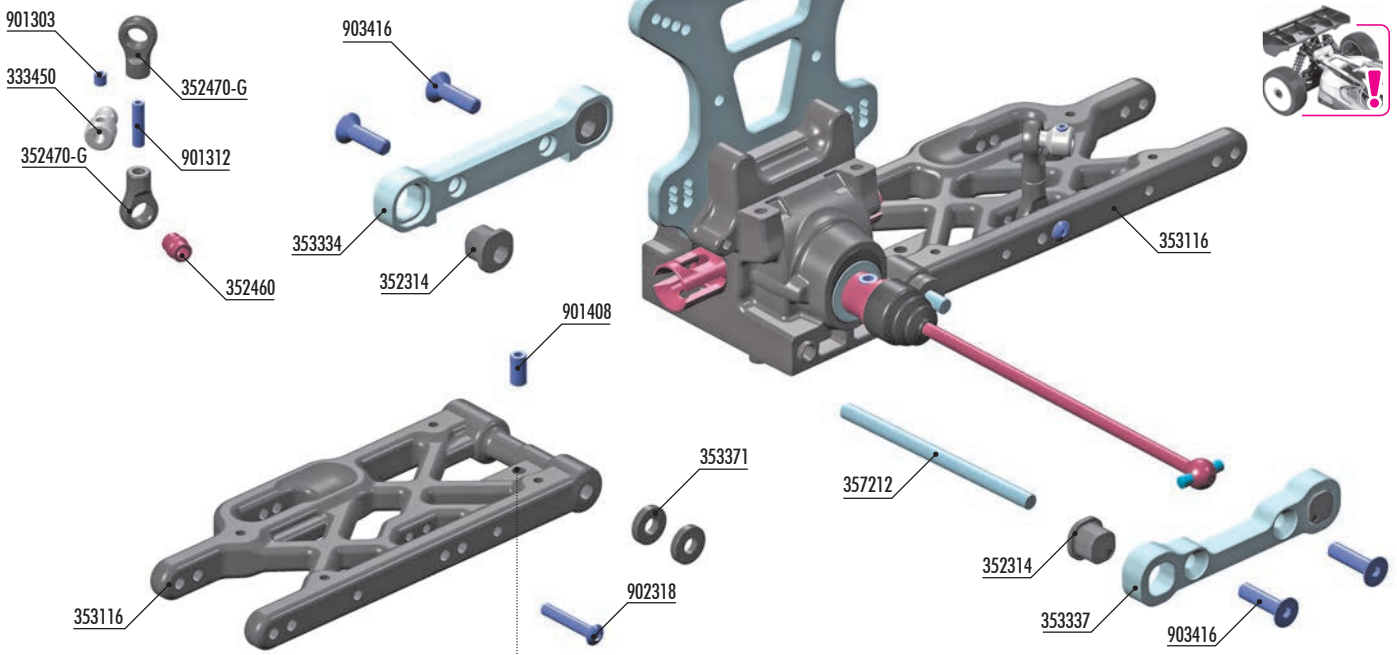
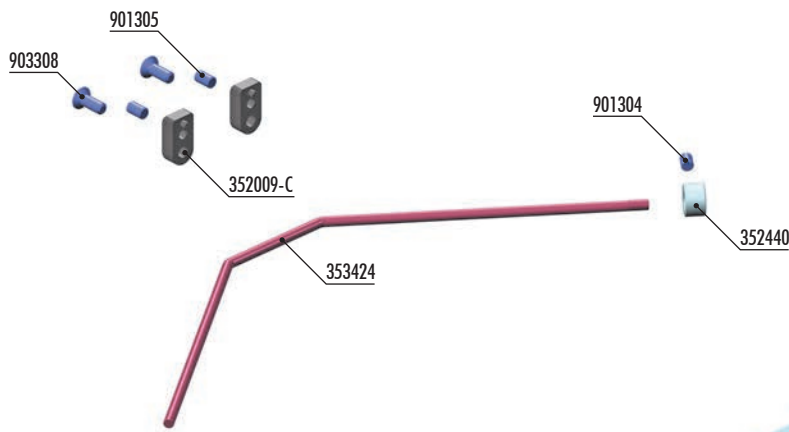

**FLAT - REAR SUSP. ARMS**

|            |          |          |
|------------|----------|----------|
| #353115    | MEDIUM   | OPTION   |
| #353116    | HARD     | INCLUDED |
| #353116-XH | X-HARD   | OPTION   |
| #353116-G  | GRAPHITE | OPTION   |



**FLAT - REAR SUSP. ARMS - SHORT**

|            |          |        |
|------------|----------|--------|
| #353127-H  | HARD     | OPTION |
| #353127-XH | X-HARD   | OPTION |
| #353127-G  | GRAPHITE | OPTION |



**LSM - REAR SUSPENSION ARMS**

|           |              |        |
|-----------|--------------|--------|
| #353124-H | HARD (R)     | OPTION |
| #353125-H | HARD (L)     | OPTION |
| #353124-G | GRAPHITE (R) | OPTION |
| #353125-G | GRAPHITE (L) | OPTION |



**#902407**  
HEX SCREW SH M4x7 WITH HEX FROM BOTTOM (4)  
**OPTION**

**#902409**  
HEX SCREW SH M4x10 WITH HEX FROM BOTTOM (4)  
**OPTION**

**#333451**  
ALU ANTI-ROLL BAR PIVOT BALL 5.8mm - SWISS 7075 T6 - HARDCOATED (2)  
**OPTION**

**REAR ANTI-ROLL BARS**

|         |        |          |
|---------|--------|----------|
| #353420 | ø2.0mm | OPTION   |
| #353422 | ø2.2mm | OPTION   |
| #353424 | ø2.4mm | INCLUDED |
| #353425 | ø2.5mm | OPTION   |
| #353426 | ø2.6mm | OPTION   |
| #353428 | ø2.8mm | OPTION   |
| #353430 | ø3.0mm | OPTION   |
| #353432 | ø3.2mm | OPTION   |

**BAG**  
**03**

- 333450 ANTI-ROLL BAR BALL JOINT 5.8mm (2)
- 352009-C SEMI-SPLIT DIFF BULKHEAD BLOCK SET FRONT/REAR FOR COLLAR
- 352314 COMPOSITE ECCENTRIC BUSHINGS - V2 (2)
- 352440 ALU ANTI-ROLL BAR COLLAR 3.5x7.8x4.9mm
- 352460 PIVOT BALL 5.8 (10)
- 352470-G COMPOSITE BALL JOINT 5.8 - GRAPHITE (8)
- 353116 COMPOSITE REAR LOWER SUSPENSION ARM - HARD
- 353334 ALU REAR LOWER SUSP. HOLDER FOR SEMI-SPLIT BULKHEAD - REAR
- 353337 ALU REAR EXTRA LOWER SUSP. HOLDER FOR SEMI-SPLIT BULKHEAD - FRONT
- 353371 SET OF COMPOSITE LOWER ARM SHIMS
- 353424 REAR ANTI-ROLL BAR 2.4mm
- 357212 LOWER INNER PIVOT PIN F+R (2)

- 901303 HEX SCREW SB M3x3 (10)
- 901304 HEX SCREW SB M3x4 (10)
- 901305 HEX SCREW SB M3x5 (10)
- 901312 HEX SCREW SB M3x12 (10)
- 901408 HEX SCREW SB M4x8 (10)
- 902318 HEX SCREW SH M3x18 (10)
- 903308 HEX SCREW SFH M3x8 (10)
- 903416 HEX SCREW SFH M4x16 (10)

Numbers in parentheses ( ) refer to quantities when purchased separately.

# 3. REAR SUSPENSION



4x 353371 SHIM 4x10x2



2x 901408 SB M4x8



4x 903416 SFH M4x16



**MEDIUM**  
SUSPENSION ARMS

❌ DO NOT use INNER positions.

**HARD**  
SUSPENSION ARMS

✅ All positions are available.

**X-HARD / GRAPHITE**  
SUSPENSION ARMS

❌ DO NOT use OUTER positions.

GRAPHITE GREASE GR

Push bushing into suspension holder until flush.

4x16mm

RR-D

4x8mm

2mm 2mm

RF-C

4x16mm

NOTE ORIENTATION

NOTE ORIENTATION

For all screws in this step.

GRAPHITE GREASE GR

Check for free movement.

**TOP** DOWNSTOP SETTING

**BOTTOM** 2.0mm

#902407 HEX SCREW SH M4x7 WITH HEX FROM BOTTOM (4)

OPTION

Downstop screw for fine tuning.

#902409 HEX SCREW SH M4x10 WITH HEX FROM BOTTOM (4)

OPTION

**TIP**

If the suspension arms DO NOT move freely, use a HUDY Arm Reamer to resize the holes.

(HUDY #107644)

ARM REAMER

INITIAL SETTING

RF

INITIAL SETTING

All possible mounting alternatives of eccentric bushings.

**ECCENTRIC BUSHINGS HAVE TWO DIFFERENT OFFSETS FROM THE CENTER.**

● Middle position = 0.5 mm or 0.5° from center.      ● Outer position = 1mm or 1° from center.

**SET-UP BOOK**

TOE-IN  
ANTI-SQUAT  
ROLL CENTER DOWNSTOP  
WHEELBASE  
TRACK WIDTH

The XRAY rear alu lower suspension holders provide even greater range of adjustment for the rear suspension. Using different combinations of eccentric bushings, fine adjustment of rear anti-squat, rear toe-in, rear roll center, and rear track-width can be obtained. For more information about the influence of rear anti-squat, rear toe-in, rear roll center and rear track width on car handling, please refer to HUDY Off-Road Set-up Book (#209099).

| ANTI-SQUAT |     |       |
|------------|-----|-------|
| RR         | RF  | (°)   |
| 0          | 0   | = 1°  |
| 0          | 0.5 | = 2°  |
| 0          | 1   | = 0°  |
| 0.5        | 0   | = 2°  |
| 0.5        | 0.5 | = 1°  |
| 0.5        | 1   | = 3°  |
| 1          | 0   | = 0°  |
| 1          | 0.5 | = 1°  |
| 1          | 1   | = -1° |

| ROLL CENTER |     |        |
|-------------|-----|--------|
| RR          | RF  | (mm)   |
| 0           | 0   | = 0mm  |
| 0           | 0.5 | = 1mm  |
| 0           | 1   | = -1mm |

| TRACK-WIDTH |     |       |
|-------------|-----|-------|
| RR          | RF  | (mm)  |
| 0           | 0   | = 308 |
| 0           | 0.5 | = 306 |
| 0           | 1   | = 310 |

| TOE-IN |     |      |
|--------|-----|------|
| RR     | RF  | (°)  |
| 0      | 0   | = 3° |
| 0      | 0.5 | = 4° |
| 0      | 1   | = 2° |
| 0.5    | 0   | = 2° |
| 0.5    | 0.5 | = 3° |
| 0.5    | 1   | = 1° |
| 1      | 0   | = 4° |
| 1      | 0.5 | = 5° |
| 1      | 1   | = 3° |

The tables describe the amounts of rear anti-squat, rear toe-in, rear track-width change depending on the combinations of eccentric bushings used with 0 and 1mm, 1° offset. The 0.5mm, 0.5° represents the half change.

**Anti-Squat Example:**

0(RR) - 0 (RF) = 1°

0(RR) - 0.5 (RF) = 1.5°

0(RR) - 1 (RF) = 2°

# 3. REAR SUSPENSION

2x 901312  
SB M3x12

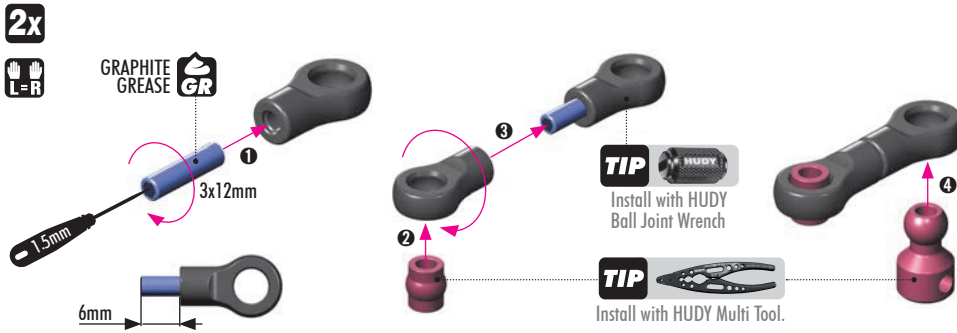

1x 901304  
SB M3x4

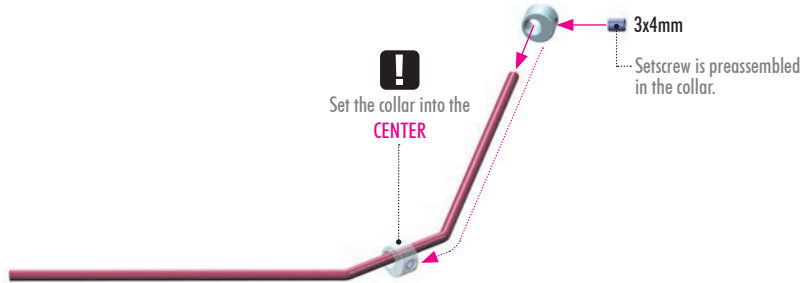

2x 901303  
SB M3x3

2x 901305  
SB M3x5

2x 902318  
SH M3x18

2x 903308  
SFH M3x8

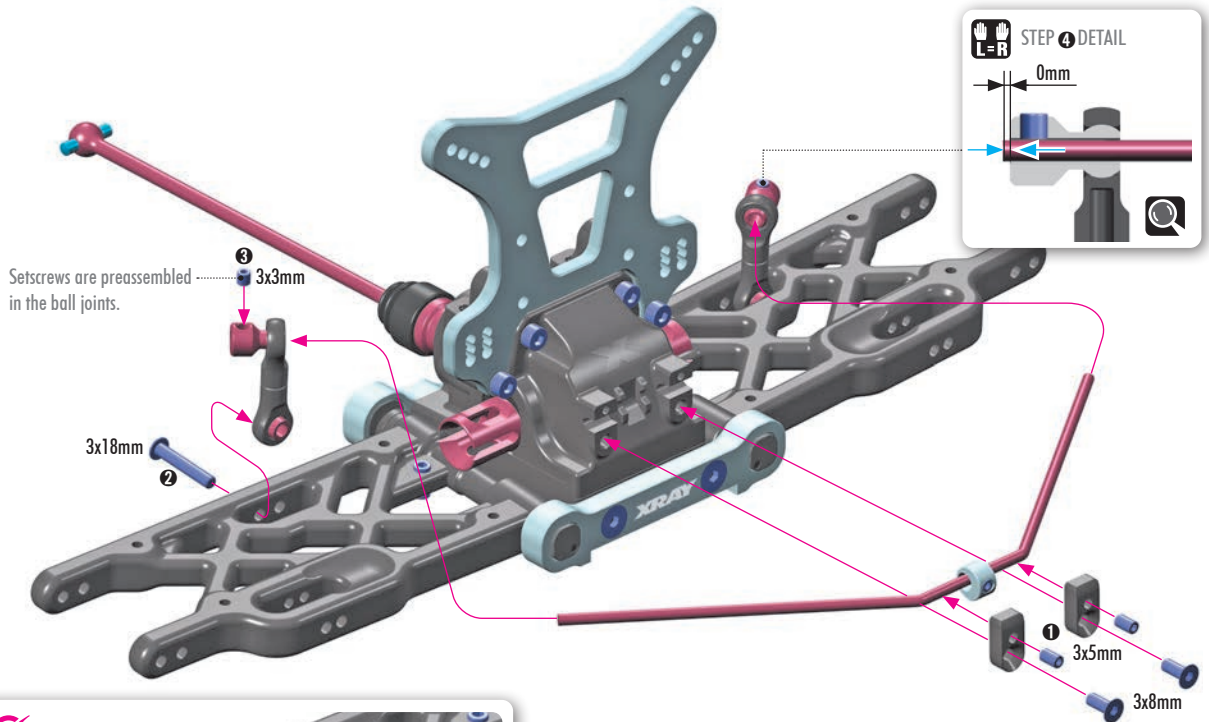

**INITIAL SETTING**

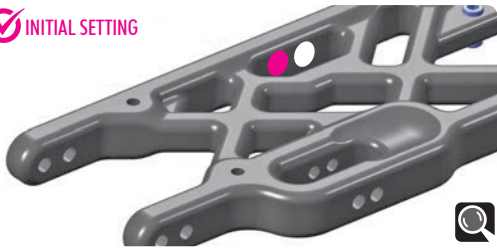

**SET-UP BOOK**  
ANTI-ROLL BAR



Loosen the 3x5mm setscrew if the anti-roll bar **DOES NOT** turn freely.

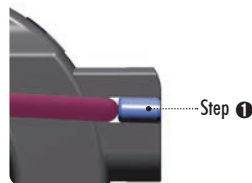

| REAR ANTI-ROLL BARS |         |        |          |
|---------------------|---------|--------|----------|
| <b>OPTION</b>       | #353420 | ø2.0mm | OPTION   |
|                     | #353422 | ø2.2mm | OPTION   |
|                     | #353424 | ø2.4mm | INCLUDED |
|                     | #353425 | ø2.5mm | OPTION   |
|                     | #353426 | ø2.6mm | OPTION   |
|                     | #353428 | ø2.8mm | OPTION   |
|                     | #353430 | ø3.0mm | OPTION   |
|                     | #353432 | ø3.2mm | OPTION   |

# 4. REAR SUSPENSION

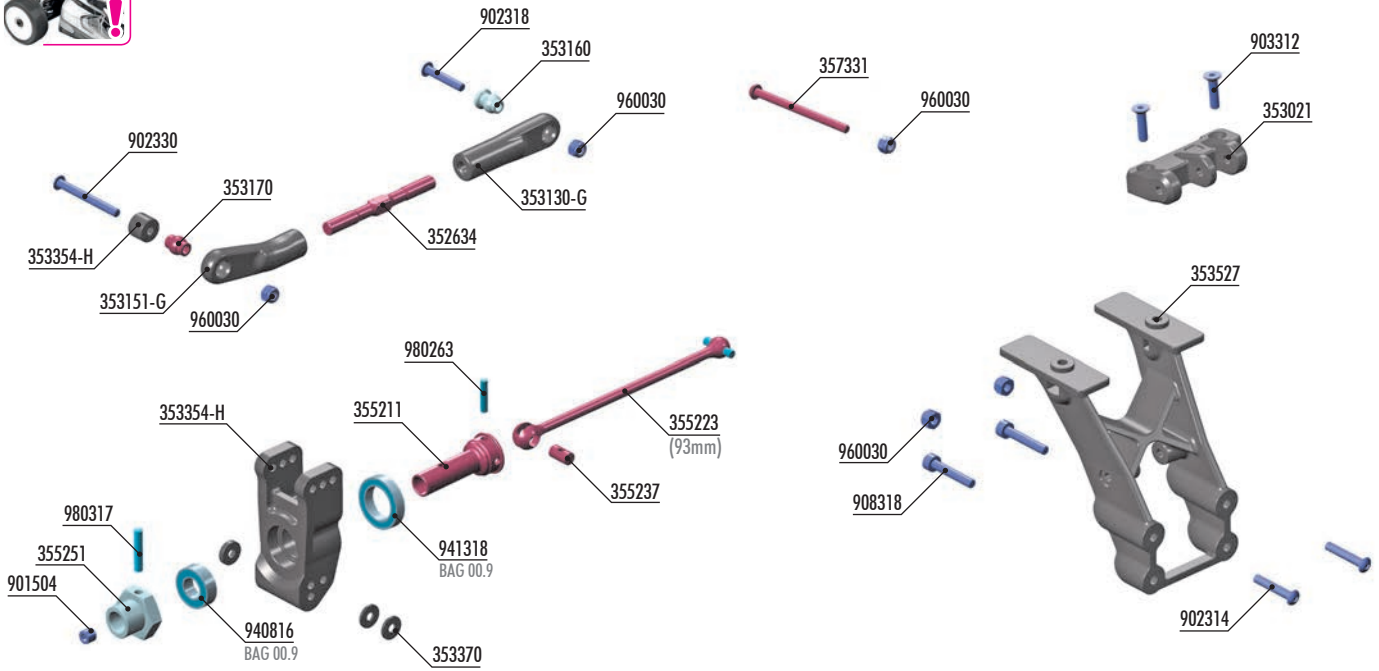

### OFFSET WHEEL AXLES

| Part #  | Offset | Status   | Image |
|---------|--------|----------|-------|
| #355250 | 0mm    | OPTION   |       |
| #355251 | +1mm   | INCLUDED |       |
| #355252 | +2mm   | OPTION   |       |
| #355253 | +3mm   | OPTION   |       |
| #355254 | +4mm   | OPTION   |       |



### REAR UPRIGHTS

| Part #    | Material | Status   | Image |
|-----------|----------|----------|-------|
| #353354   | MEDIUM   | OPTION   |       |
| #353354-H | HARD     | INCLUDED |       |
| #353354-G | GRAPHITE | OPTION   |       |
| #350912   | ALU-SET  | OPTION   |       |



### XRAY BALL-BEARINGS

| Part #  | Size    | Seal   | Material | Status   | Image |
|---------|---------|--------|----------|----------|-------|
| #930816 | 8x16x5  | GREASE | STEEL    | OPTION   |       |
| #940816 | 8x16x5  | GREASE | RUBBER   | INCLUDED |       |
| #931318 | 13x19x4 | GREASE | STEEL    | OPTION   |       |
| #941318 | 13x19x4 | GREASE | RUBBER   | INCLUDED |       |
| #930817 | 8x16x5  | OIL    | STEEL    | OPTION   |       |
| #940817 | 8x16x5  | OIL    | RUBBER   | OPTION   |       |
| #931319 | 13x19x4 | OIL    | STEEL    | OPTION   |       |
| #941319 | 13x19x4 | OIL    | RUBBER   | OPTION   |       |



### #355222 UNIVERSAL DRIVE SHAFT - HUDY SPRING STEEL™



### #355215 CVD ADJUSTABLE DRIVE AXLE - HUDY SPRING STEEL™



### #350912 XB8 ALU REAR UPRIGHTS - MULTI-ADJUSTABLE - SET INCLUDING #353394 CARBON EXTENSION

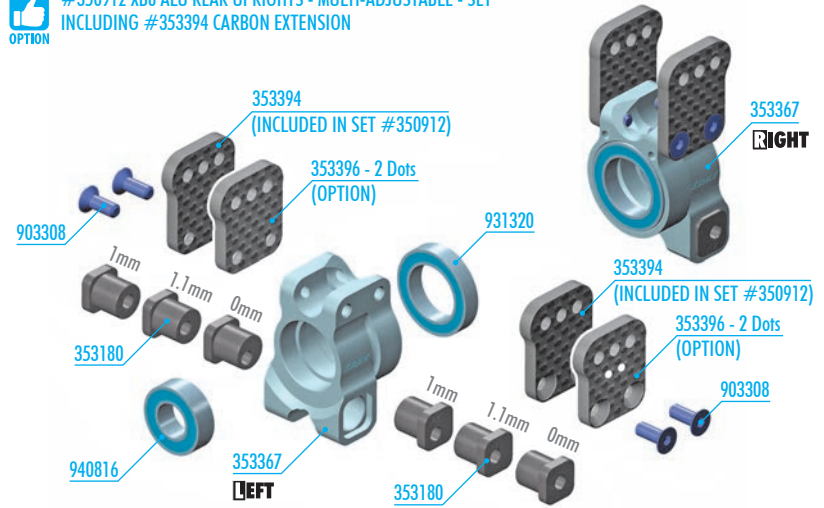

- 352634 ADJ. TURNBUCKLE M5 L/R 50mm - HUDY SPRING STEEL™ (2)
- 353021 COMPOSITE REAR BRACE HOLDER WITH TWO ASSEMBLY POSITIONS
- 353130-G REAR UPPER INNER CAMBER LINK BALL JOINT - GRAPHITE (2)
- 353151-G RELIEF REAR UPPER OUTER CAMBER LINK BALL JOINT - GRAPHITE (2)
- 353160 MOUNTING BALL 6.8 (4)
- 353170 PIVOT BALL 6.8 (4)
- 353354-H COMPOSITE REAR UPRIGHT - HARD
- 353370 SET OF COMPOSITE REAR HUB CARRIER SHIMS
- 353527 COMPOSITE REAR WING HOLDER - EXTENDED SUPPORT AREA
- 355211 CVD DRIVE AXLE - HUDY SPRING STEEL™
- 355223 CVD UNIVERSAL DRIVE SHAFT 93mm - HUDY SPRING STEEL™
- 355237 CVD DRIVE SHAFT COUPLING - HUDY SPRING STEEL™
- 355251 ALU WHEEL AXLE OFFSET "+1mm"- BLACK COATED (2)

- 357331 REAR LOWER OUTER PIVOT PIN SCREW 3mm (2)
- 901504 HEX SCREW SB M5x4 (10)
- 902314 HEX SCREW SH M3x14 (10)
- 902318 HEX SCREW SH M3x18 (10)
- 902330 HEX SCREW SH M3x30 (10)
- 903312 HEX SCREW SFH M3x12 (10)
- 908318 HEX SCREW SOCKET HEAD CAP SCH M3x18 (10)
- 940816 BALL-BEARING 8x16x5 RUBBER SEALED - GREASE (2)
- 941318 BALL-BEARING 13x19x4 RUBBER SEALED - GREASE (2)
- 960030 NUT M3 (10)
- 980263 PIN 2.5x13 (10)
- 980317 PIN 3x17 (10)

Numbers in parentheses ( ) refer to quantities when purchased separately.

# 4. REAR SUSPENSION

-  2x 901504 SB M5x4
-  2x 940816 BB 8x16x5
-  2x 941318 BB 13x19x4
-  2x 980263 P 2.5x13
-  2x 980317 P 3x17

**2x**  **L=R**

**NOTE ORIENTATION** 

**93mm SHORT CVD DRIVE SHAFT**

**TIP** Follow the TECH TIP on page 6 for drive shaft pin servicing.

**GRAPHITE GREASE** 

**TIP** To tighten the setscrew, you can use the HUDY 17mm Wheel Nut Tool #107570.

**Be careful NOT to overtighten the setscrew, as excessive tension in the drive axle may cause it to break. Instead, use thread lock to secure the setscrew.**

**2.5x13mm**

**3x17mm**

**8x16x5mm**

**5x4mm**

**13x19x4mm**

**5x4mm**



**THREAD LOCK** 

**#355215 CVD ADJUSTABLE DRIVE AXLE - HUDY SPRING STEEL™**

**OPTION** 

Drive shaft position

4 | 3 | 2 | 1

-  4x 353370 SHIM 3x9x1
-  2x 353370 SHIM 3x9x2
-  2x 960030 N M3

**TIP** Before tightening the pivot pin locknut, ensure the rear upright moves freely. If it DOES NOT move freely, lightly sand both wheelbase shims and recheck for bind.

**2x**  **L=R**

Shims for wheelbase adjustment 1 + 1mm

**2mm**

**M3**

**ASSEMBLED VIEW**

**INITIAL SETTING**

**Check for free movement.**

**TIP** DO NOT overtighten the self-locking nut. Overtightening may result in suspension bind.

**Use THREAD LOCK to secure the M3 nut.**

**TIP**  **L=R** **ARM REAMER** (HUDY #107643)

If the rear upright DOES NOT move freely, use a HUDY Arm Reamer to resize the hole.

**1** Install pivot balls with HUDY Multi Tool.

**2** Install ball joints on turnbuckle.

**TIP**  Install with HUDY Multi Tool.

**NOTE ORIENTATION** 

**GRAPHITE GREASE**  **RIGHT THREAD**

**LEFT THREAD**  **GRAPHITE GREASE**

**RIGHT THREAD** 26.5mm **LEFT THREAD**

**LEFT THREAD** 26.5mm **RIGHT THREAD**

**RIGHT**

**LEFT**

**TIP** Use tools to tighten as shown.

Special Tool for all turnbuckles & nuts (HUDY #181090) or Turnbuckle Wrench 5mm (HUDY #181050).

**SET-UP BOOK**  
CAMBER

# 4. REAR SUSPENSION



2x 353354-H  
SHIM 3x9x7



2x 902318  
SH M3x18

2x 902330  
SH M3x30



4x 960030  
N M3

2x L=R

PIVOT BALL  
NOTE ORIENTATION



ASSEMBLED VIEW

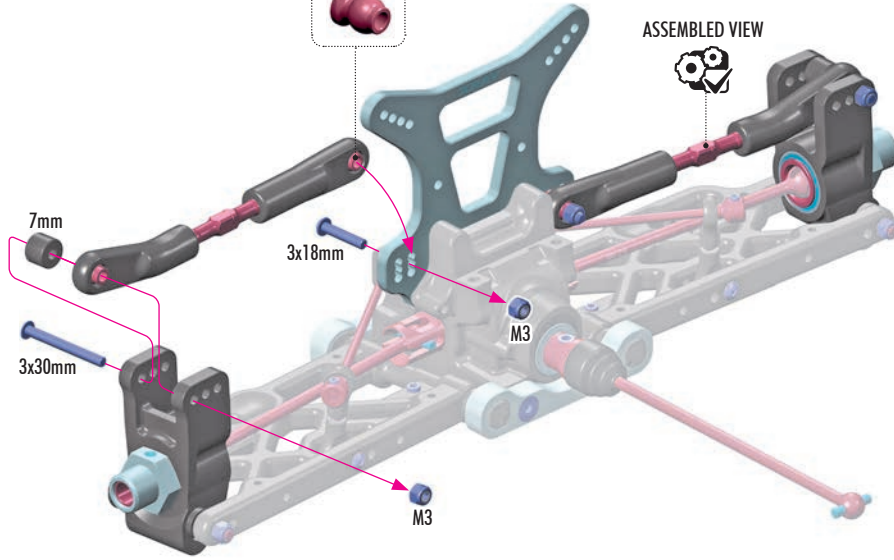

L=R

INITIAL SETTING

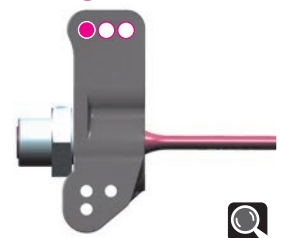

2x 903312  
SFH M3x12

3x12mm

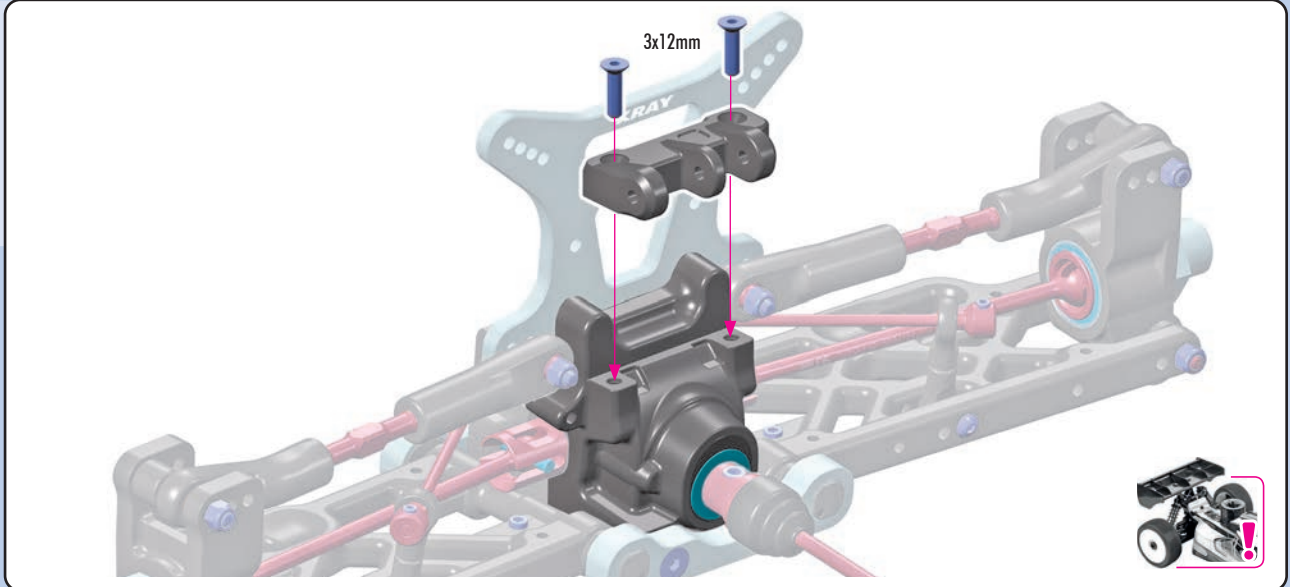

2x 902314  
SH M3x14

2x 908318  
SCH M3x18



2x 960030  
N M3

3x14mm

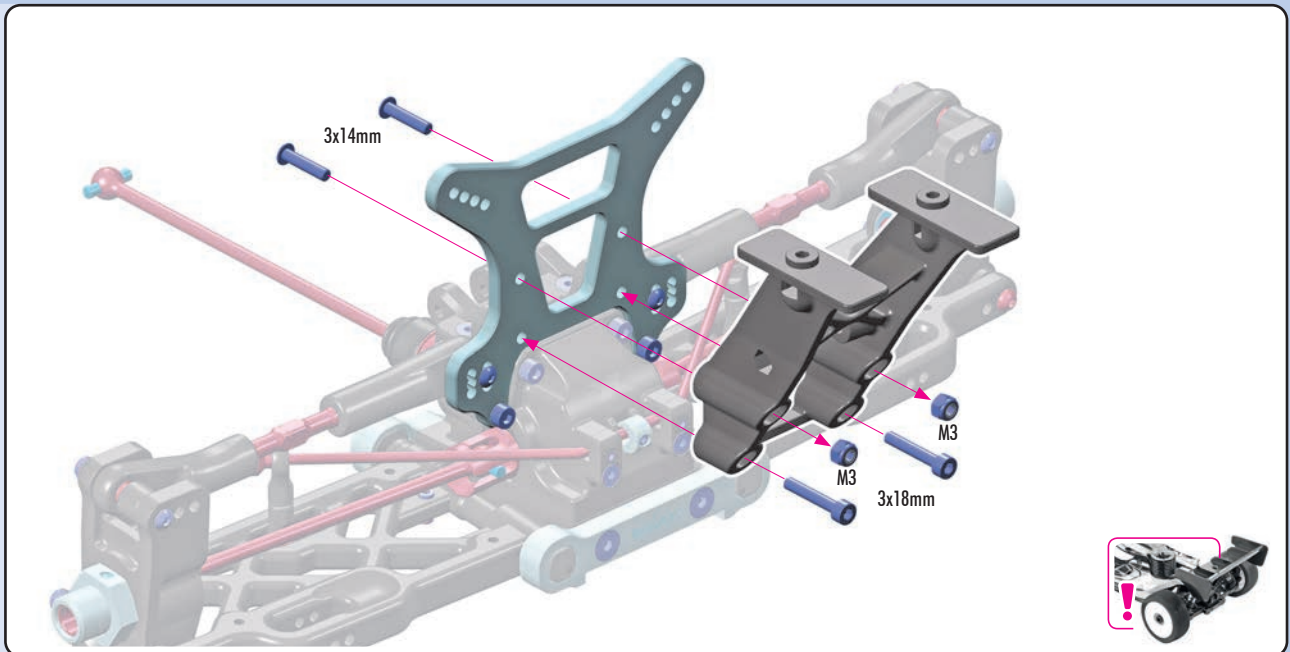

# 5. FRONT SUSPENSION

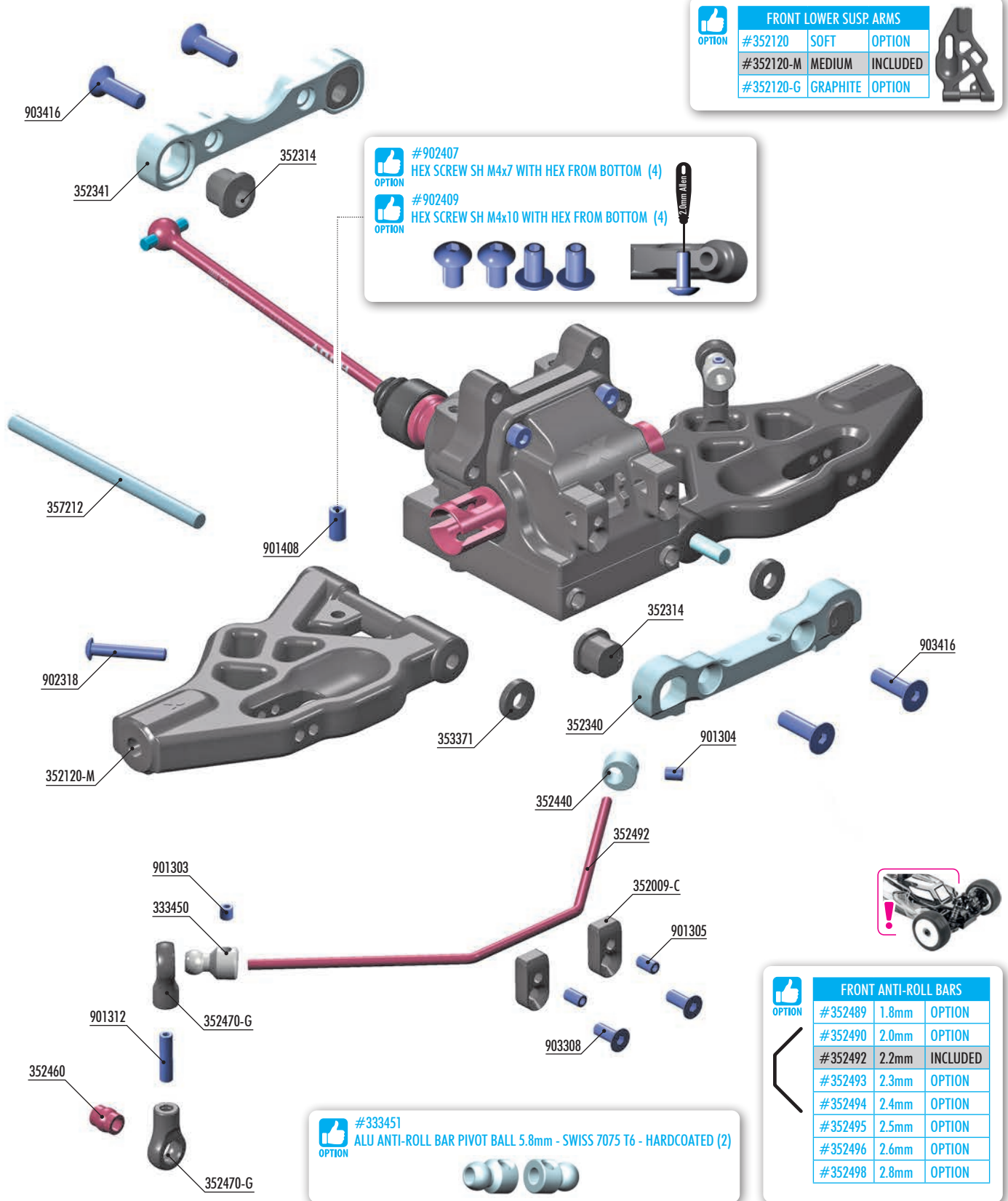

| FRONT LOWER SUSP. ARMS |           |          |          |
|------------------------|-----------|----------|----------|
| OPTION                 | #352120   | SOFT     | OPTION   |
|                        | #352120-M | MEDIUM   | INCLUDED |
|                        | #352120-G | GRAPHITE | OPTION   |

#902407  
 HEX SCREW SH M4x7 WITH HEX FROM BOTTOM (4)  
 OPTION

#902409  
 HEX SCREW SH M4x10 WITH HEX FROM BOTTOM (4)  
 OPTION

| FRONT ANTI-ROLL BARS |         |       |          |
|----------------------|---------|-------|----------|
| OPTION               | #352489 | 1.8mm | OPTION   |
|                      | #352490 | 2.0mm | OPTION   |
|                      | #352492 | 2.2mm | INCLUDED |
|                      | #352493 | 2.3mm | OPTION   |
|                      | #352494 | 2.4mm | OPTION   |
|                      | #352495 | 2.5mm | OPTION   |
|                      | #352496 | 2.6mm | OPTION   |
|                      | #352498 | 2.8mm | OPTION   |

#333451  
 ALU ANTI-ROLL BAR PIVOT BALL 5.8mm - SWISS 7075 T6 - HARDCOATED (2)  
 OPTION

**BAG**  
**05**

- |          |  |        |                               |
|----------|--|--------|-------------------------------|
| 333450   | ANTI-ROLL BAR BALL JOINT 5.8mm (2)                           | 357212 | LOWER INNER PIVOT PIN F+R (2) |
| 352009-C | SEMI-SPLIT DIFF BULKHEAD BLOCK SET FRONT/REAR FOR COLLAR     | 901303 | HEX SCREW SB M3x3 (10)        |
| 352120-M | COMPOSITE FRONT LOWER SUSPENSION ARM - MEDIUM                | 901304 | HEX SCREW SB M3x4 (10)        |
| 352314   | COMPOSITE SQUARE ADJ. ROLL CENTER BUSHINGS - V2 (2)          | 901305 | HEX SCREW SB M3x5 (10)        |
| 352340   | ALU FRONT LOWER SUSP. HOLDER FOR SEMI-SPLIT BULKHEAD - FRONT | 901312 | HEX SCREW SB M3x12 (10)       |
| 352341   | ALU FRONT LOWER SUSP. HOLDER FOR SEMI-SPLIT BULKHEAD - REAR  | 901408 | HEX SCREW SB M4x8 (10)        |
| 352440   | ALU ANTI-ROLL BAR COLLAR 3.5x7.8x4.9mm (2)                   | 902318 | HEX SCREW SH M3x18 (10)       |
| 352460   | PIVOT BALL 5.8 (10)  | 903308 | HEX SCREW SFH M3x8 (10)       |
| 352470-G | COMPOSITE BALL JOINT 5.8 - GRAPHITE (8)                      | 903416 | HEX SCREW SFH M4x16 (10)      |
| 352492   | FRONT ANTI-ROLL BAR 2.4mm                                    |        |                               |
| 353371   | SET OF COMPOSITE LOWER ARM SHIMS                             |        |                               |

Numbers in parentheses ( ) refer to quantities when purchased separately.

# 5. FRONT SUSPENSION

10

2x 353371 SHIM 4x10x2

2x 901408 SB M4x8

4x 903416 SFH M4x16

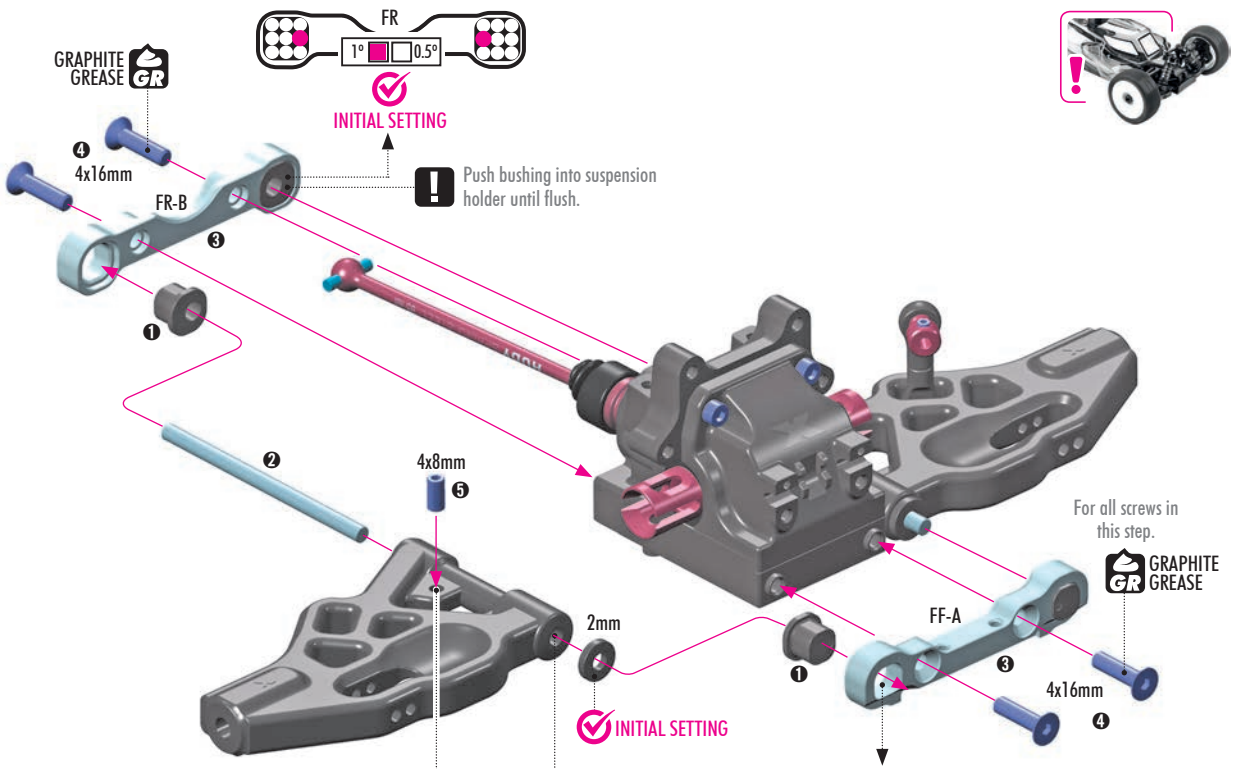

**TOP** DOWNSTOP SETTING

**L=R**

**BOTTOM** 1.0mm

#902407 HEX SCREW SH M4x7 WITH HEX FROM BOTTOM (4)

OPTION

Downstop screw for fine tuning.

#902409 HEX SCREW SH M4x10 WITH HEX FROM BOTTOM (4)

OPTION

**TIP** **L=R**

If suspension arms DO NOT pivot freely after checking eccentric bushings, a HUDY arm reamer can eliminate any remaining bind.

(HUDY #107644)

ARM REAMER

**FF** INITIAL SETTING

All possible mounting alternatives of eccentric bushings.

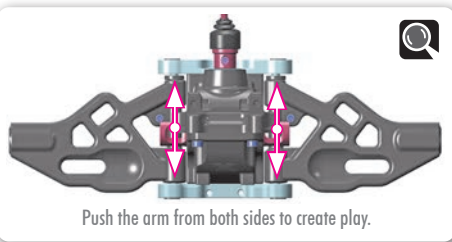
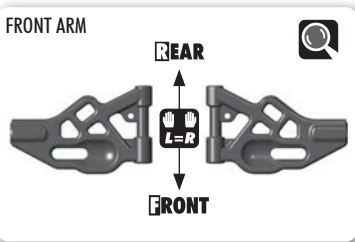

Eccentric bushings have two different offsets from the center.

- Middle position = 0.5 mm or 0.5° from center
- Outer position = 1mm or 1° from center

| FF | FR | (mm)  |
|----|----|-------|
|    |    | =308  |
|    |    | =306  |
|    |    | =310* |

| FF | FR | (mm) |
|----|----|------|
|    |    | =1   |
|    |    | =0   |
|    |    | =-1  |

The XRAY alu front lower suspension holders provide even greater range of adjustment for the front suspension. Using different combinations of eccentric bushings, fine adjustment of front kick-up, roll center, and front track-width can be obtained. For more information about the influence of kick-up, front track-width, and roll centers on car handling, please refer to HUDY Off-Road Set-up Book (#209099).

The tables above describe the changes to kick-up and front track width when using the 0 and 1mm/1deg offset bushings. The .5mm/.5deg bushings reduce setting changes by half.

\* NOT recommended to use this setting.

**SET-UP BOOK**  
KICK UP  
ROLL CENTER DOWNSTOP  
WHEELBASE  
TRACK WIDTH

# 5. FRONT SUSPENSION

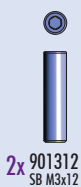

2x



GRAPHITE GREASE GR

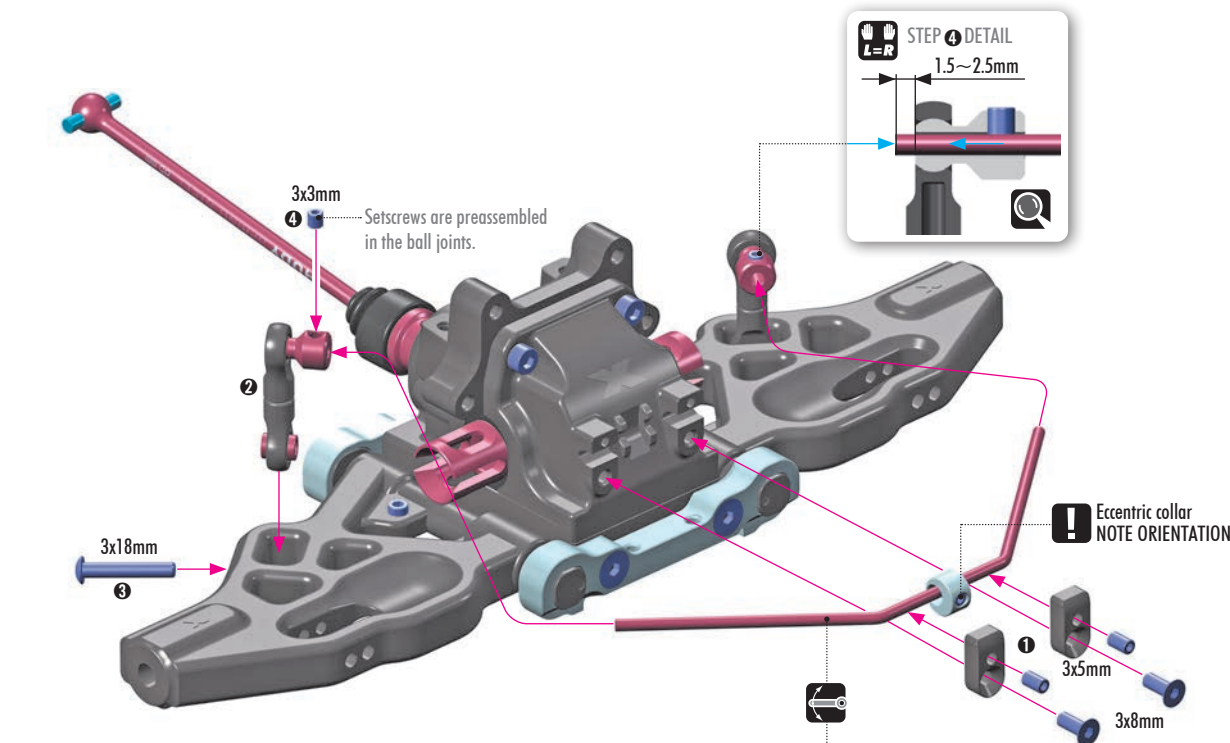
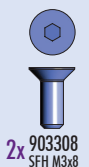
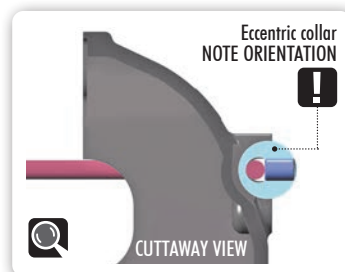
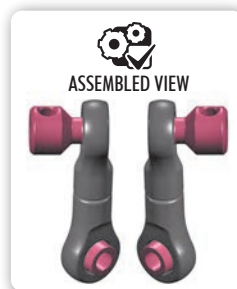
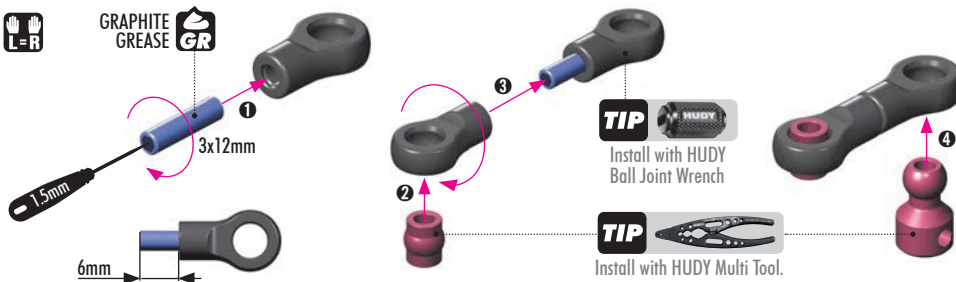

### FRONT ANTI-ROLL BARS

|         |       |          |
|---------|-------|----------|
| #352489 | 1.8mm | OPTION   |
| #352490 | 2.0mm | OPTION   |
| #352492 | 2.2mm | INCLUDED |
| #352493 | 2.3mm | OPTION   |
| #352494 | 2.4mm | OPTION   |
| #352495 | 2.5mm | OPTION   |
| #352496 | 2.6mm | OPTION   |
| #352498 | 2.8mm | OPTION   |

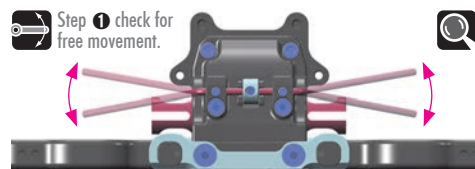
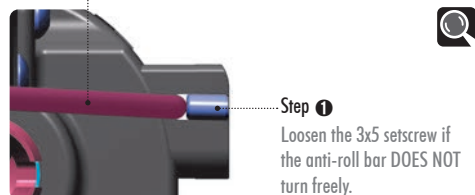

SET-UP BOOK  
ANTI-ROLL BAR

# 6. FRONT SUSPENSION

**#357257 PIVOT BALL CAMBER**  
ALU SHIM 6x13x1.5mm (2)

**#352194 LEXAN® FRONT UPPER ARM WINGS IFMAR LEGAL - SET**

**#357253 BRASS ADJUSTING NUT M15x1**

**OFFSET WHEEL AXLES**

| #       | Offset | Status   |
|---------|--------|----------|
| #355250 | 0mm    | OPTION   |
| #355251 | +1mm   | INCLUDED |
| #355252 | +2mm   | OPTION   |
| #355253 | +3mm   | OPTION   |
| #355254 | +4mm   | OPTION   |

**FRONT UPPER SUSP. ARMS**

| #         | Material | Status   |
|-----------|----------|----------|
| #352135   | SOFT     | OPTION   |
| #352135-M | MEDIUM   | INCLUDED |
| #352135-G | GRAPHITE | OPTION   |

**STEERING BLOCKS**

| #         | Material | Status   |
|-----------|----------|----------|
| #352244   | MEDIUM   | OPTION   |
| #352244-H | HARD     | INCLUDED |
| #352244-G | GRAPHITE | OPTION   |

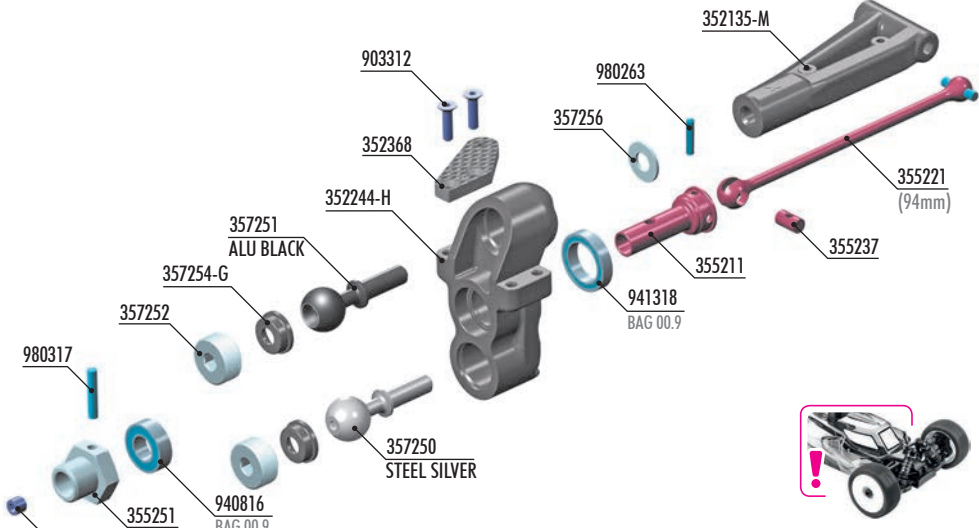

**STEERING PLATES**

| #       | Pattern | Material | Status   |
|---------|---------|----------|----------|
| #352366 | 1 DOT   | CARBON   | OPTION   |
| #352367 | 2 DOTS  | CARBON   | OPTION   |
| #352368 | 3 DOTS  | CARBON   | INCLUDED |
| #352372 | 1 DOT   | ALU      | OPTION   |
| #352370 | 2 DOTS  | ALU      | OPTION   |

**XRAY BALL-BEARINGS**

| #       | Size    | Lubricant | Material | Status   |
|---------|---------|-----------|----------|----------|
| #930816 | 8x16x5  | GREASE    | STEEL    | OPTION   |
| #940816 | 8x16x5  | GREASE    | RUBBER   | INCLUDED |
| #931318 | 13x19x4 | GREASE    | STEEL    | OPTION   |
| #941318 | 13x19x4 | GREASE    | RUBBER   | INCLUDED |
| #930817 | 8x16x5  | OIL       | STEEL    | OPTION   |
| #940817 | 8x16x5  | OIL       | RUBBER   | OPTION   |
| #931319 | 13x19x4 | OIL       | STEEL    | OPTION   |
| #941319 | 13x19x4 | OIL       | RUBBER   | OPTION   |



- |  |  |
|--|--|
| 352135-M FRONT UPPER ARM - MEDIUM                          | 357252 ALU ADJUSTING NUT M15x1 (2)                     |
| 352244-H PB STEERING BLOCK LB - HARD                       | 357254-G COMPOSITE BALL CUP 13.9mm - GRAPHITE (2)      |
| 352368 CARBON STEERING PLATE - 3 DOTS (1+1)                | 357256 ALU SHIM 6x13x1 (2)                             |
| 355211 CVD DRIVE AXLE - HUDY SPRING STEEL™                 | 901504 HEX SCREW SB M5x4 (10)                          |
| 355221 CVD UNIVERSAL DRIVE SHAFT 94mm - HUDY SPRING STEEL™ | 903312 HEX SCREW SFH M3x12 (10)                        |
| 355237 CVD DRIVE SHAFT COUPLING - HUDY SPRING STEEL™       | 940816 BALL-BEARING 8x16x5 RUBBER SEALED - GREASE (2)  |
| 355251 ALU WHEEL AXLE OFFSET "+1mm" - HARD COATED (2)      | 941318 BALL-BEARING 13x19x4 RUBBER SEALED - GREASE (2) |
| 357250 STEEL PIVOT BALL 13.7mm (2)                         | 980263 PIN 2.5x13 (10)                                 |
| 357251 ALU PIVOT BALL 13.7mm WITH STEEL SCREW (2)          | 980317 PIN 3x17 (10)                                   |

Numbers in parentheses ( ) refer to quantities when purchased separately.

- 2x 901504 SB M5x4
- 2x 940816 BB 8x16x5
- 2x 941318 BB 13x19x4
- 2x 980263 P 2.5x13
- 2x 980317 P 3x17

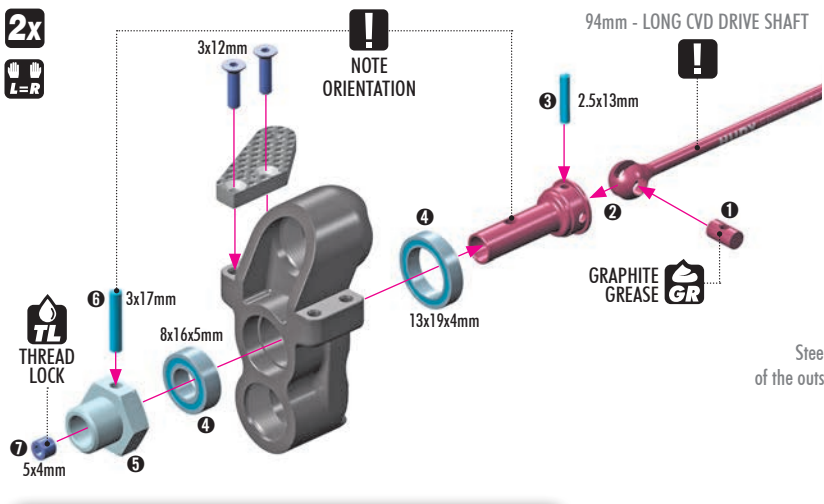

**#355222 UNIVERSAL DRIVE SHAFT - HUDY SPRING STEEL™**

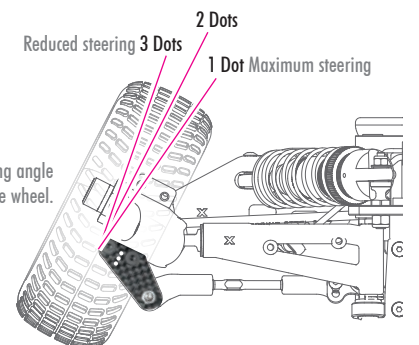

**TIP**

To tighten the setscrew you can also use the (HUDY 17mm Wheel Nut Tool #107570).

**Be careful NOT to overtighten the setscrew, as excessive tension in the drive axle may cause it to break. Instead, use thread lock to secure the setscrew.**

**STEERING PLATES**

| #       | Pattern | Material | Status   |
|---------|---------|----------|----------|
| #352366 | 1 DOT   | CARBON   | OPTION   |
| #352367 | 2 DOTS  | CARBON   | OPTION   |
| #352368 | 3 DOTS  | CARBON   | INCLUDED |
| #352372 | 1 DOT   | ALU      | OPTION   |
| #352370 | 2 DOTS  | ALU      | OPTION   |

# 6. FRONT SUSPENSION

**2x**

**!** ALU pivot ball  
BLACK color

**!** STEEL pivot ball  
SILVER color

**TIP** Tighten hex nuts using HUDY tool #107581.

**OPTION** #357253 BRASS ADJUSTING NUT M15x1

**PIVOT BALLS MUST MOVE FREELY**  
During initial assembly, tighten each hex nut until the pivot ball starts to bind, then loosen slightly. Verify that the pivot balls move freely.

**2x**

357256  
SHIM 6x13x1

**2x**

Lexan® Wings (NOT INCLUDED)

**OPTION** #352194 XB8 LEXAN® FRONT UPPER ARM WINGS IFMAR LEGAL - SET

3x6mm

1mm

**TIP** HUDY Tool Allen 2.5mm

**OPTION** #357257 PIVOT BALL CAMBER ALU SHIM 6x13x1.5mm (2)

| FRONT UPPER SUSP. ARMS |          |          |
|------------------------|----------|----------|
| <b>OPTION</b> #352135  | SOFT     | OPTION   |
| #352135-M              | MEDIUM   | INCLUDED |
| #352135-G              | GRAPHITE | OPTION   |

**SET-UP BOOK**  
CAMBER  
TRACK-WIDTH

**2x**

**ASSEMBLED VIEW**

**TIP** HUDY Tool Allen 2.5mm

**SET-UP BOOK**  
ROLL CENTER

# 6. FRONT & REAR ASSEMBLY

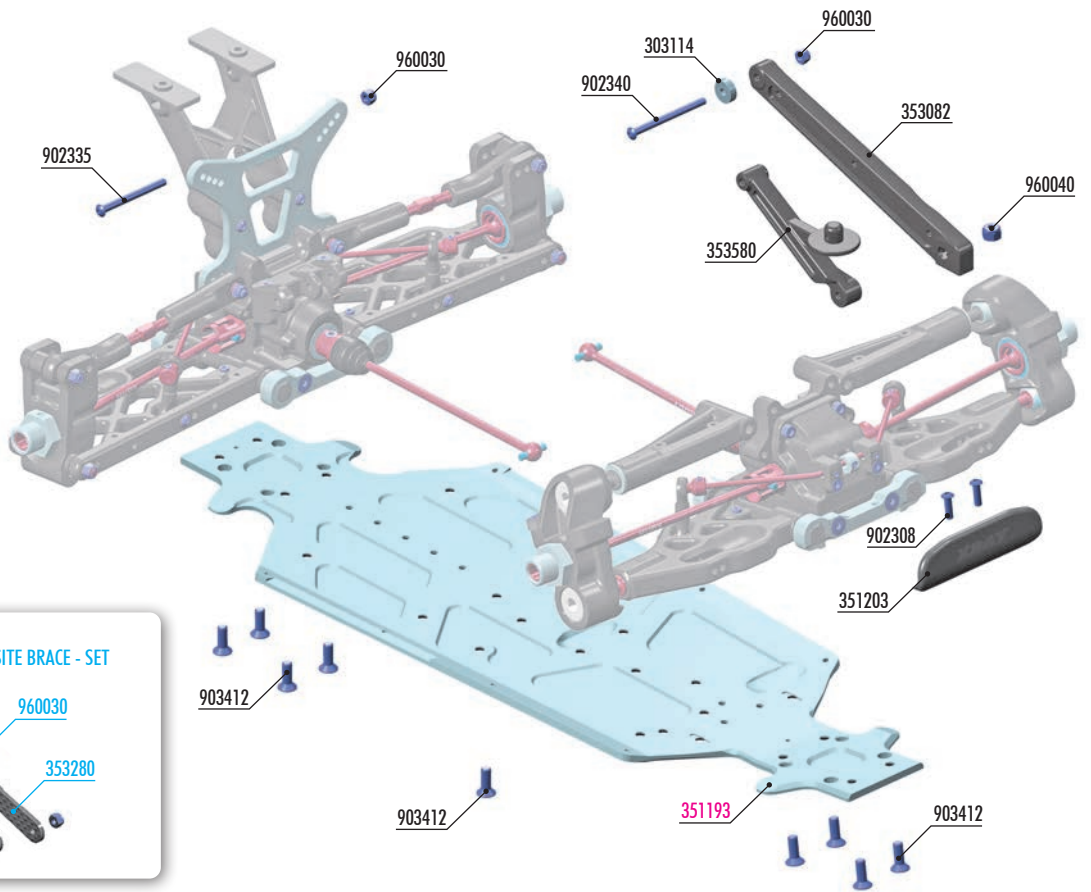
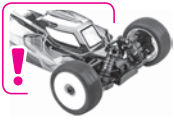

#353280  
CARBON BRACES FOR REAR COMPOSITE BRACE - SET

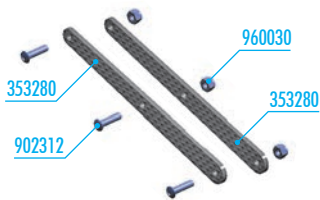

BAG

06

- 303114 ALU SHIM 3x10x3mm (10)
- 351203 COMPOSITE FRONT BUMPER FOR SEMI-SPLIT BULKHEAD
- 353082 COMPOSITE REAR BRACE - MEDIUM - M
- 353580 COMPOSITE WING HOLDER BRACE WITH REAR BODY POST

- 902340 HEX SCREW SH M3x40 (10)
- 903412 HEX SCREW SFH M4x12 (10)
- 960030 NUT M3 (10)
- 960040 NUT M4 (10)

- 902308 HEX SCREW SH M3x8 (10)
- 902335 HEX SCREW SH M3x35 (10)

- 351193 ALU CHASSIS FOR NARROW & LOWER BATTERY POSITION - SWISS 7075 T6 (3mm)

Numbers in parentheses ( ) refer to quantities when purchased separately.

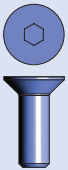

4x 903412  
SFH M4x12

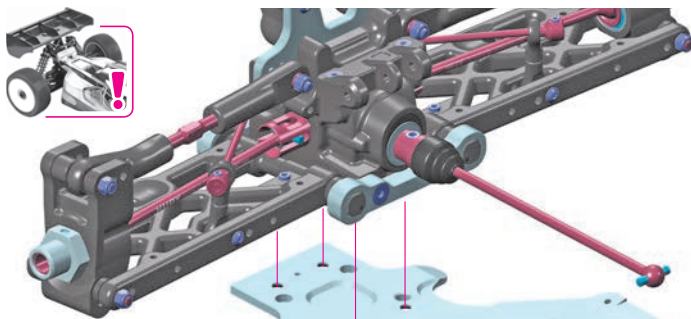

#293084  
PRECISION BALANCING CHASSIS WEIGHTS 10G (4)



#293085  
HUDY PURE TUNGSTEN WEIGHT - 10g



Locations for weights



#351236  
STAINLESS STEEL CHASSIS  
PROTECTOR - REAR



4x12mm  
GRAPHITE  
GREASE



During INITIAL assembly, there is NO need to check gear mesh or diff play. Fitment should NOT be checked until suspension holders are installed on the bulkheads and the complete assembly is mounted to the chassis. All parts have specifically designed tolerances for proper operation once fully assembled. After assembly, check for free rotation of all drivetrain parts and non-binding movement of the suspension.



# 7. STEERING



**#352658**  
**OPTION** BALL STUD 6.8mm WITH BACKSTOP L=6mm - M3x8 (2)

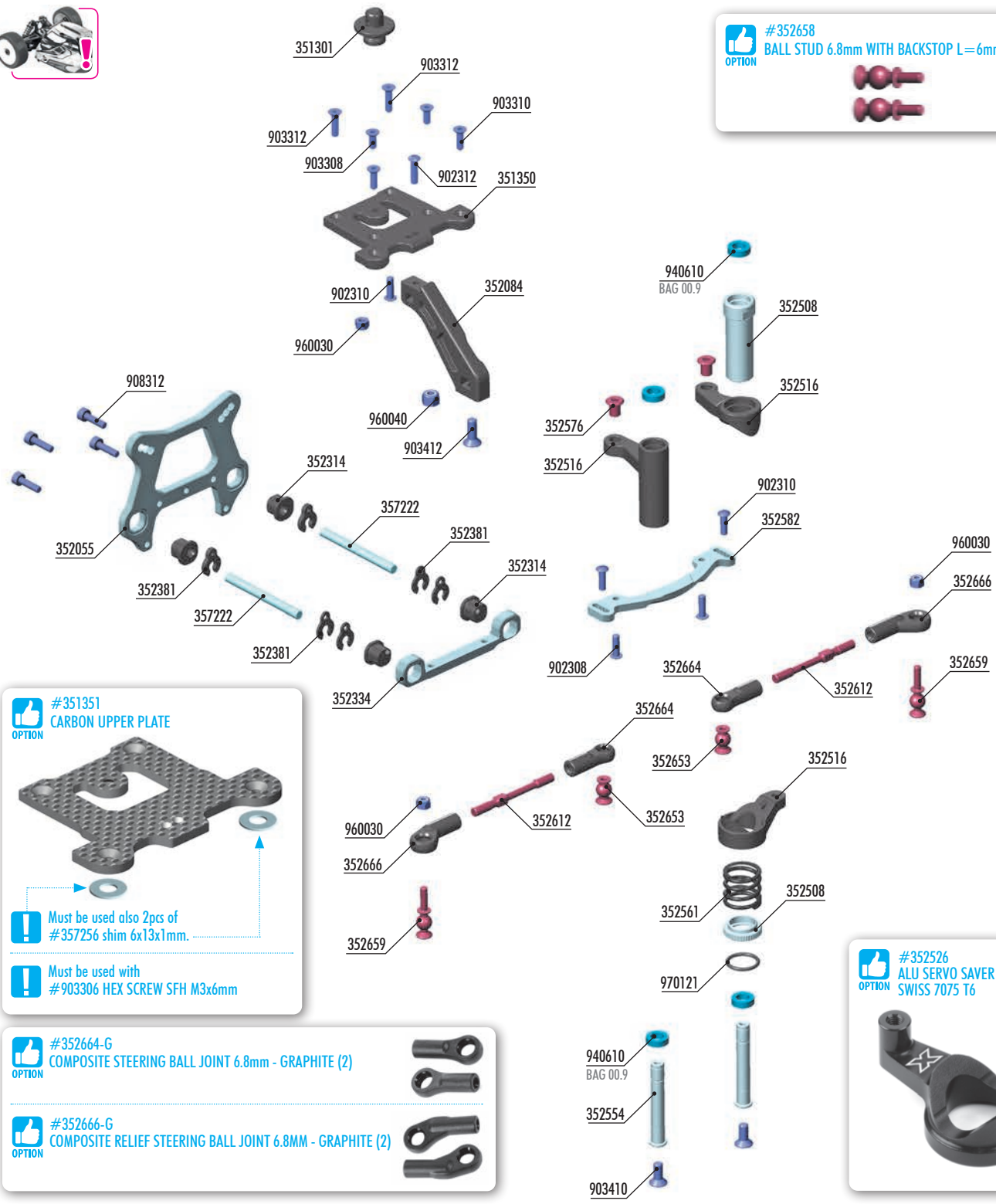

**#351351**  
**OPTION** CARBON UPPER PLATE

Must be used also 2pcs of #357256 shim 6x13x1mm.

Must be used with #903306 HEX SCREW SFH M3x6mm

**#352664-G**  
**OPTION** COMPOSITE STEERING BALL JOINT 6.8mm - GRAPHITE (2)

**#352666-G**  
**OPTION** COMPOSITE RELIEF STEERING BALL JOINT 6.8MM - GRAPHITE (2)

**#352526**  
**OPTION** ALU SERVO SAVER LOWER ARM SWISS 7075 T6

**BAG**  
**07**

|        |  |        |  |
|--------|--|--------|--|
| 351301 | BODY POSTS   | 352666 | COMPOSITE RELIEF STEERING BALL JOINT 6.8mm (2) |
| 351350 | COMPOSITE UPPER PLATE WITH TWO BRACE POSITIONS             | 357222 | FRONT UPPER PIVOT PIN 4x45 (2)                 |
| 352055 | ALU FRONT SHOCK TOWER FOR SEMI-SPLIT BULKHEAD - LOWER      | 902308 | HEX SCREW SH M3x8 (10)                         |
| 352084 | COMPOSITE FRONT BRACE                                      | 902310 | HEX SCREW SH M3x10 (10)                        |
| 902314 | COMPOSITE SQUARE ADJ. ROLL CENTER BUSHINGS - V2 (2)        | 902312 | HEX SCREW SH M3x12 (10)                        |
| 352334 | ALU FRONT UPPER ARM HOLDER FOR SEMI-SPLIT BULKHEAD         | 903308 | HEX SCREW SFH M3x8 (10)                        |
| 352381 | CASTER CLIPS (2)   | 903310 | HEX SCREW SFH M3x10 (10)                       |
| 352508 | SERVO SAVER FOR SEMI-SPLIT BULKHEAD - GRAPHITE - SET       | 903312 | HEX SCREW SFH M3x12 (10)                       |
| 352516 | COMPOSITE SERVO SAVER FOR SEMI-SPLIT BULKHEAD - GRAPHITE   | 903410 | HEX SCREW SFH M4x10 (10)                       |
| 352554 | ALU SERVO SAVER PIVOT SHAFT WITH CHASSIS LOCK (2)          | 903412 | HEX SCREW SFH M4x12 (10)                       |
| 352561 | SERVO SAVER SPRING PROGRESSIVE                             | 908312 | HEX SCREW SOCKET HEAD CAP SCH M3x12 (10)       |
| 352576 | STEERING PLATE BUSHING (2)                                 | 940610 | BALL-BEARING 6x10x3 RUBBER SEALED - OIL (2)    |
| 352582 | ALU STEERING PLATE FOR SEMI-SPLIT BULKHEAD - SWISS 7075 T6 | 960030 | NUT M3 (10)                                    |
| 352612 | ADJ. TURNBUCKLE M4 L/R 45mm - HUDY SPRING STEEL™ (2)       | 960040 | NUT M4 (10)                                    |
| 352653 | BALL STUD 6.8mm WITH BACKSTOP - M3 (2)                     | 970121 | O-RING 12.1 x 1.6 (10)                         |
| 352659 | BALL STUD 6.8mm WITH BACKSTOP L=6mm - M3x11 (2)            |        |  |
| 352664 | COMPOSITE STEERING BALL JOINT 6.8mm - V3 (2)               |        |  |

Numbers in parentheses ( ) refer to quantities when purchased separately.

# 7. STEERING



1x 970121  
O 12.1x1.6

✓ INITIAL PRELOAD SETTING

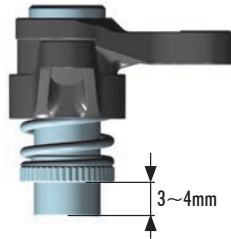

LARGER diameter on TOP  
NOTE SPRING ORIENTATION  
SMALLER diameter on BOTTOM



#352526  
ALU SERVO SAVER LOWER ARM  
OPTION SWISS 7075 T6



SET-UP BOOK  
SERVO SAVER

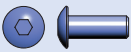

2x 902308  
SH M3x8

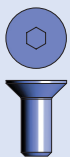
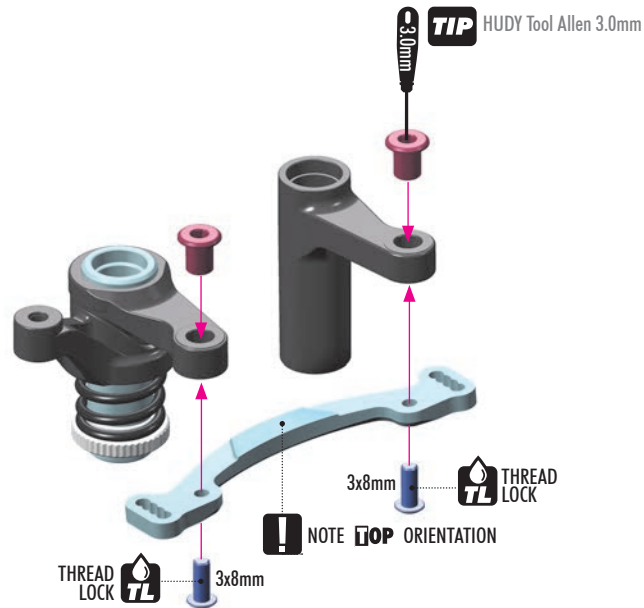

2x 903410  
SFH M4x10



4x 940610  
BB 6x10x3

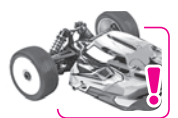
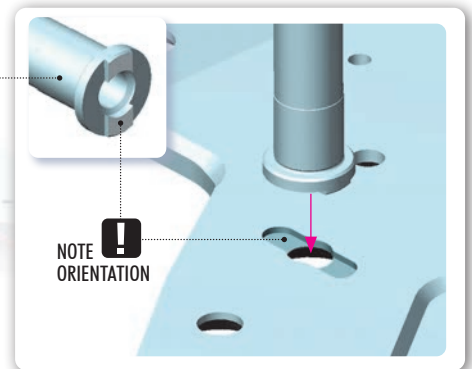
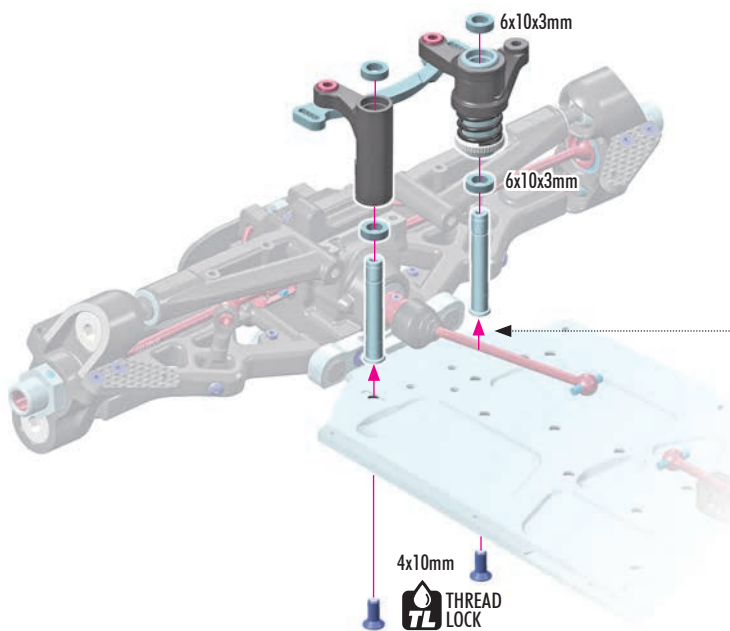

# 7. STEERING



1x 902310  
SH M3x10



2x 903308  
SFH M3x8

All possible mounting alternatives of eccentric bushings.

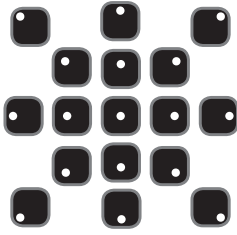

**INITIAL SETTING**

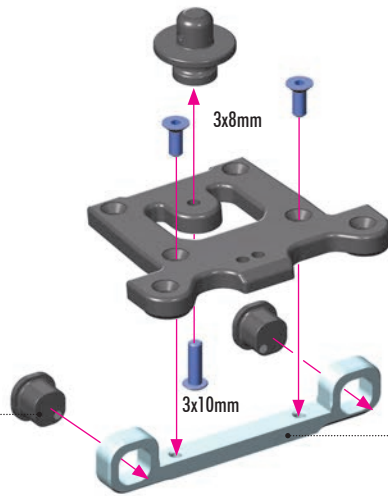

NOTE ORIENTATION

**SET-UP BOOK**  
ROLL CENTER



1x 902312  
SH M3x12



2x 903310  
SFH M3x10

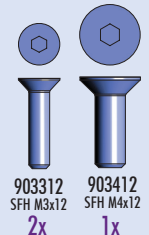

2x 903312 SFH M3x12  
1x 903412 SFH M4x12



1x 960030  
N M3



1x 960040  
N M4

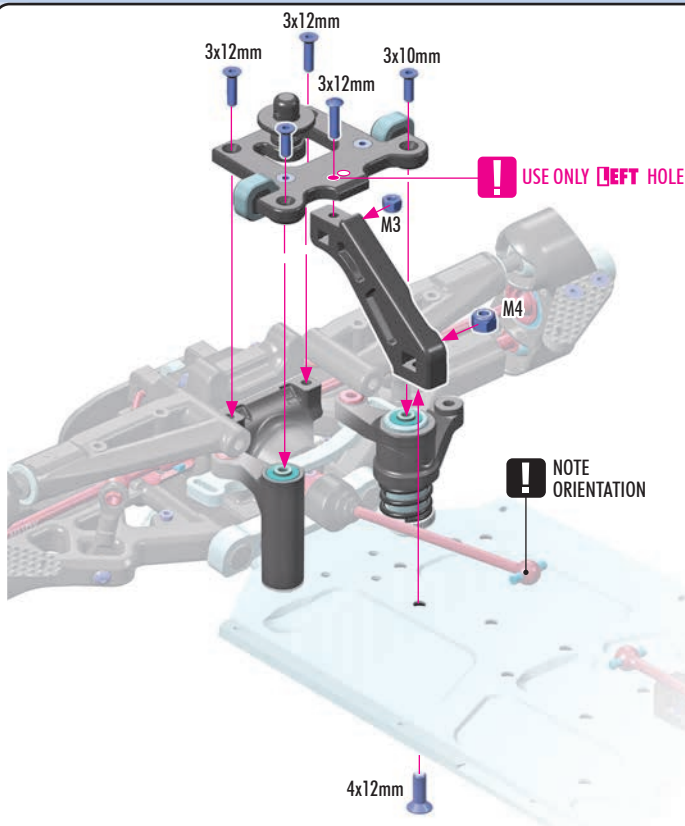

USE ONLY LEFT HOLE

NOTE ORIENTATION

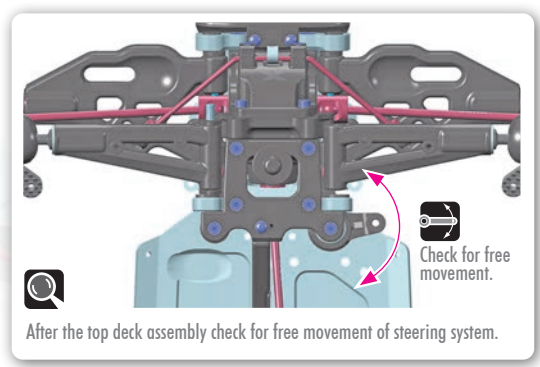
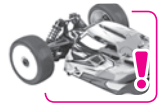

After the top deck assembly check for free movement of steering system.

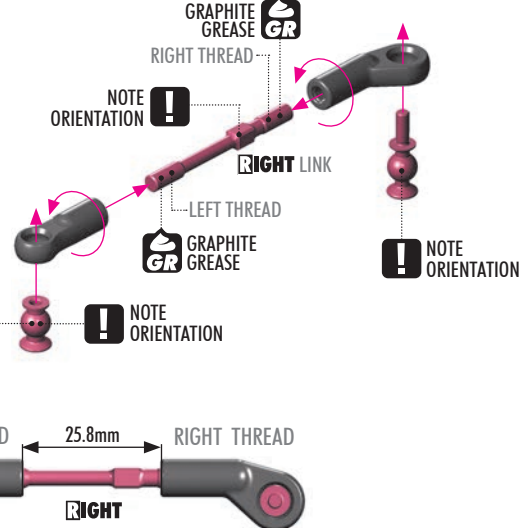
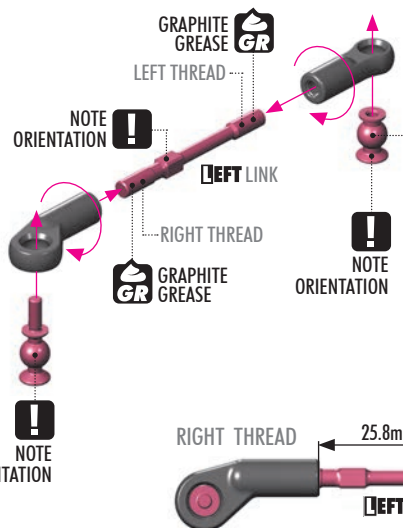

**TIP**  
Install with HUDY Multi Tool.

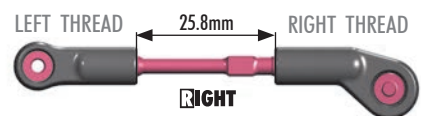
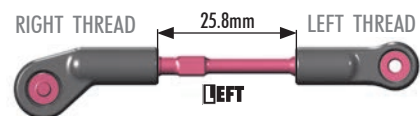

# 7. STEERING

4x 908312  
SCH M3x12

**INITIAL SETTING**  
1 + 1mm 2mm

**!** XRAY logo towards the front.

1mm 1mm 2mm 3x12mm

**INITIAL SETTING**  
1° 0.5°

All possible mounting alternatives of eccentric bushings.

| CASTER                  |                         |
|-------------------------|-------------------------|
| UPPER CLIP (Behind arm) | LOWER SHIM (Behind arm) |
|                         | 2mm                     |
| 4mm                     | 21°                     |
| 3mm                     | 22.5°                   |
| 2mm                     | 24°                     |
| 1mm                     | 25.5°                   |
| 0                       | 27°                     |

UPPER CLIP Behind arm

LOWER SHIM Behind arm

CASTER

**SET-UP BOOK**  
ROLL CENTER  
CASTER

2x 902310  
SH M3x10

2x 960030  
N M3

2x L-R

**INITIAL SETTING**

**!** NOTE ORIENTATION  
Adjustment block towards outside.

3x10mm

M3

**!** NOTE ORIENTATION  
Adjustment block towards outside.

Check for free movement.

Check for free movement.

**SET-UP BOOK**  
ACKERMANN  
BUMP STEER  
TOE-IN

# 8. CENTER DIFF & MOTOR

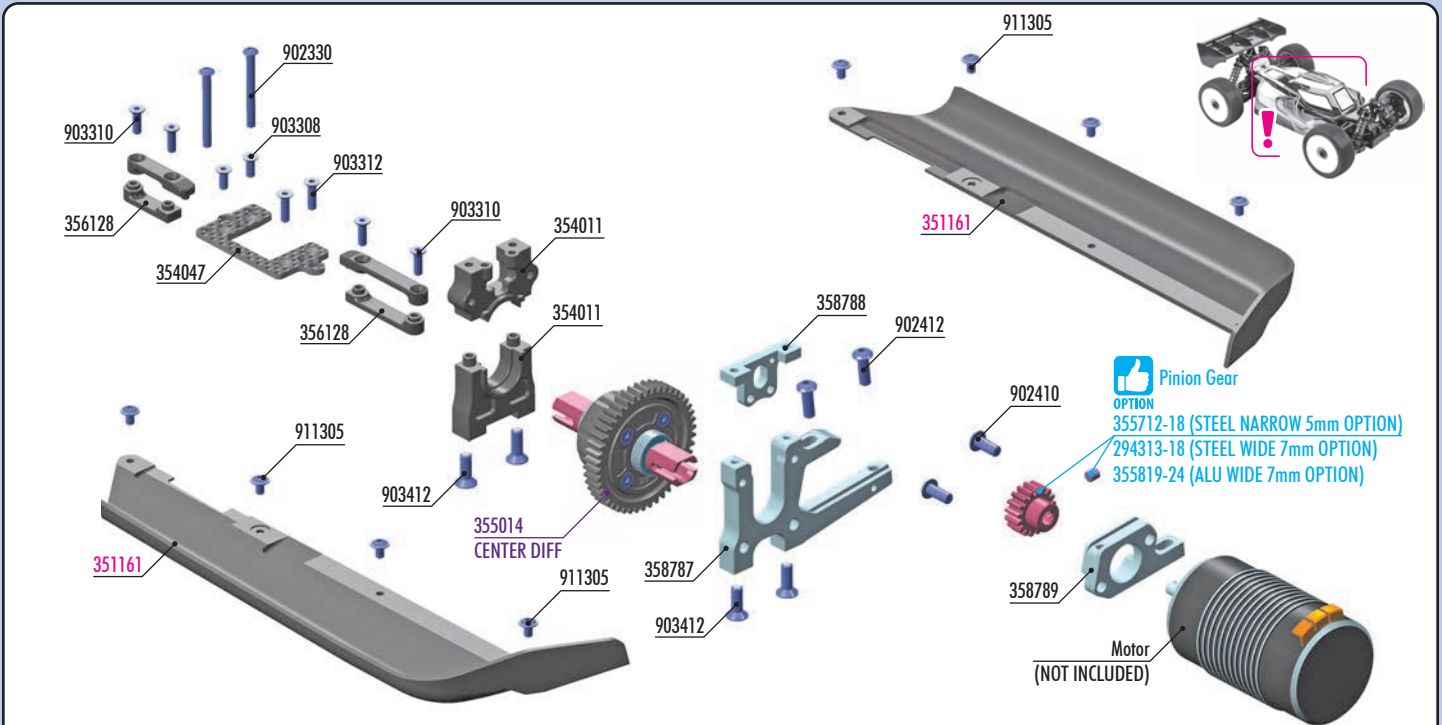

**Pinion Gear**  
 OPTION  
 355712-18 (STEEL NARROW 5mm OPTION)  
 294313-18 (STEEL WIDE 7mm OPTION)  
 355819-24 (ALU WIDE 7mm OPTION)

**#293190**  
 ALU MULTI-FAN MOUNT FOR 42mm MOTOR  
 OPTION

3x14mm INCLUDED

**#293104**  
 HUDY ALU RC FAN 40mm - BOTTOM/SIDE MOUNT 2 HOLE  
 OPTION

**#293111**  
 HUDY BRUSHLESS RC FAN 40mm WITH EXTERNAL SOLDERING TABS  
 OPTION

**#293113**  
 HUDY BRUSHLESS RC FAN 40mm WITH INTERNAL SOLDERING TABS  
 OPTION

**BAG**  
**08**

|           |  |        |  |
|-----------|--|--------|--|
| 354011    | CENTER DIFF MOUNTING PLATE SET - HIGHER            | 902410 | HEX SCREW SH M4x10 (10)                                      |
| 354047    | CARBON CENTER DIFF PLATE FOR SPLIT DIFF MOUNT      | 902412 | HEX SCREW SH M4x12 (10)                                      |
| 355712~18 | STEEL 12~18T PINION GEAR - NARROW (OPTION)         | 903308 | HEX SCREW SFH M3x8 (10)                                      |
| 355819~24 | ALU 19~24T PINION GEAR - WIDE (OPTION)             | 903310 | HEX SCREW SFH M3x10 (10)                                     |
| 294313~18 | STEEL 13~18 PINION GEAR - WIDE (OPTION)            | 903312 | HEX SCREW SFH M3x12 (10)                                     |
| 356128    | COMPOSITE HOLDER FOR CABLES - SET                  | 903412 | HEX SCREW SFH M4x12 (10)                                     |
| 358787    | ALU CENTER DIFF & MOTOR MOUNT FOR SPLIT DIFF MOUNT | 911305 | HEX SCREW FLANGED SH M3x5 (10)                               |
| 358788    | ALU MOTOR MOUNT UPPER CLAMP FOR SPLIT DIFF MOUNT   | 351161 | CHASSIS SIDE GUARDS - NARROW & LOWER BATTERY POSITION L+R    |
| 358789    | ALU MOTOR MOUNT PLATE FOR SPLIT DIFF MOUNT         | 355014 | CENTER DIFFERENTIAL SMALL WITH COMPOSITE SPUR GEAR 46T - SET |
| 902330    | HEX SCREW SH M3x30 (10)                            |        |  |

Numbers in parentheses ( ) refer to quantities when purchased separately.

**4x** 911305  
 SHF M3x5

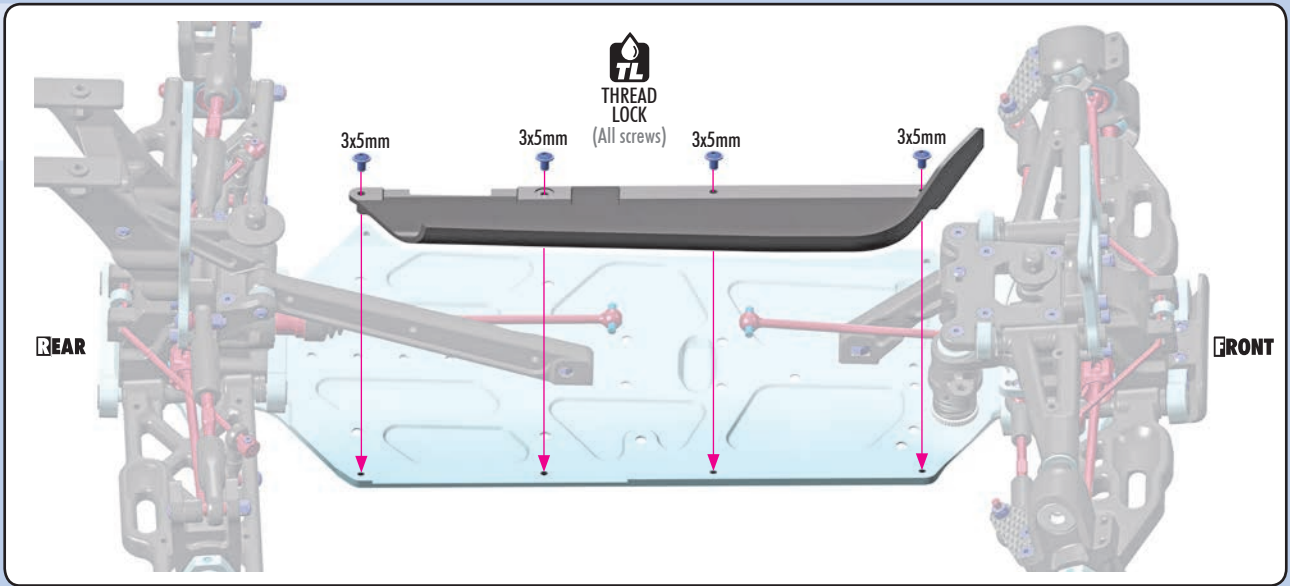

# 8. CENTER DIFF & BRAKE

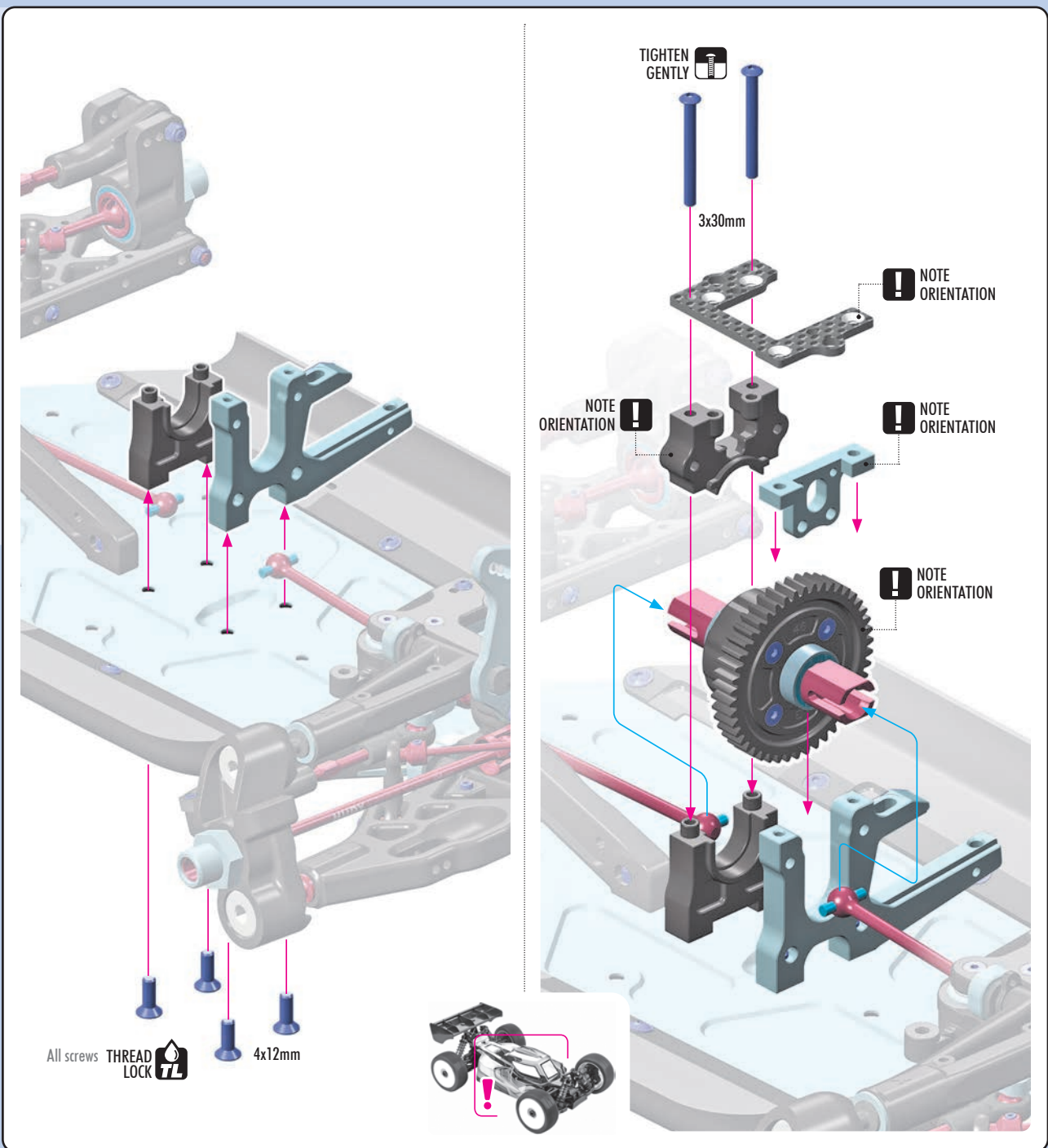
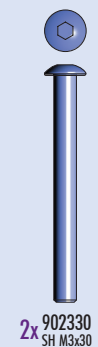
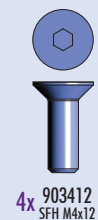
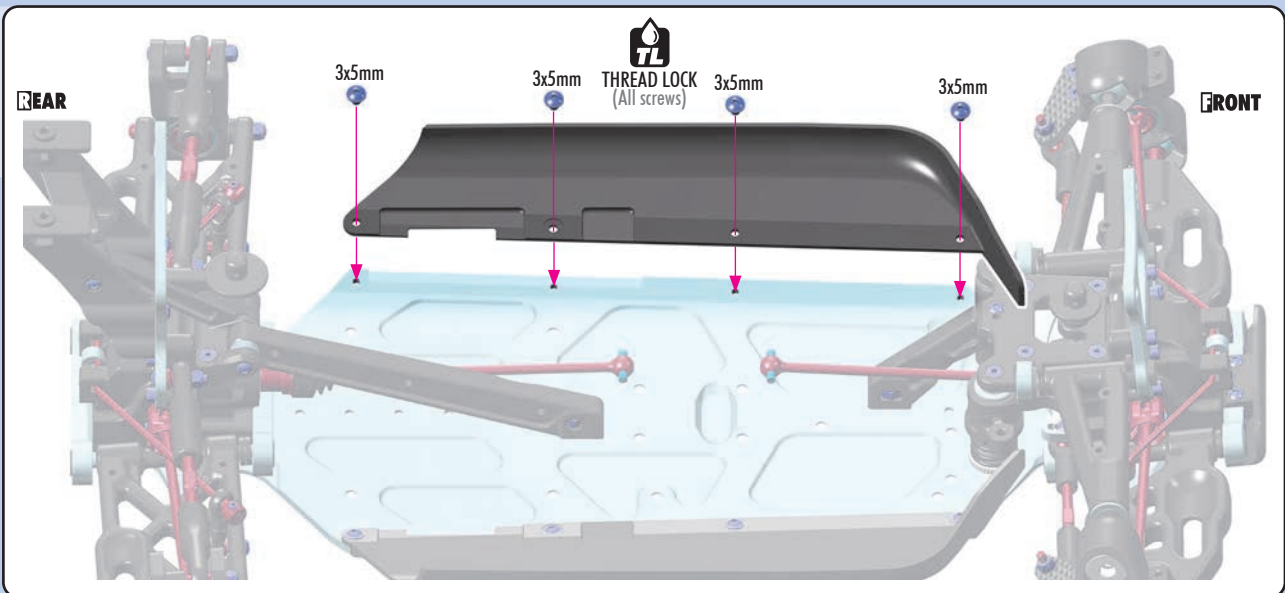

# 8. CENTER DIFF & BRAKE

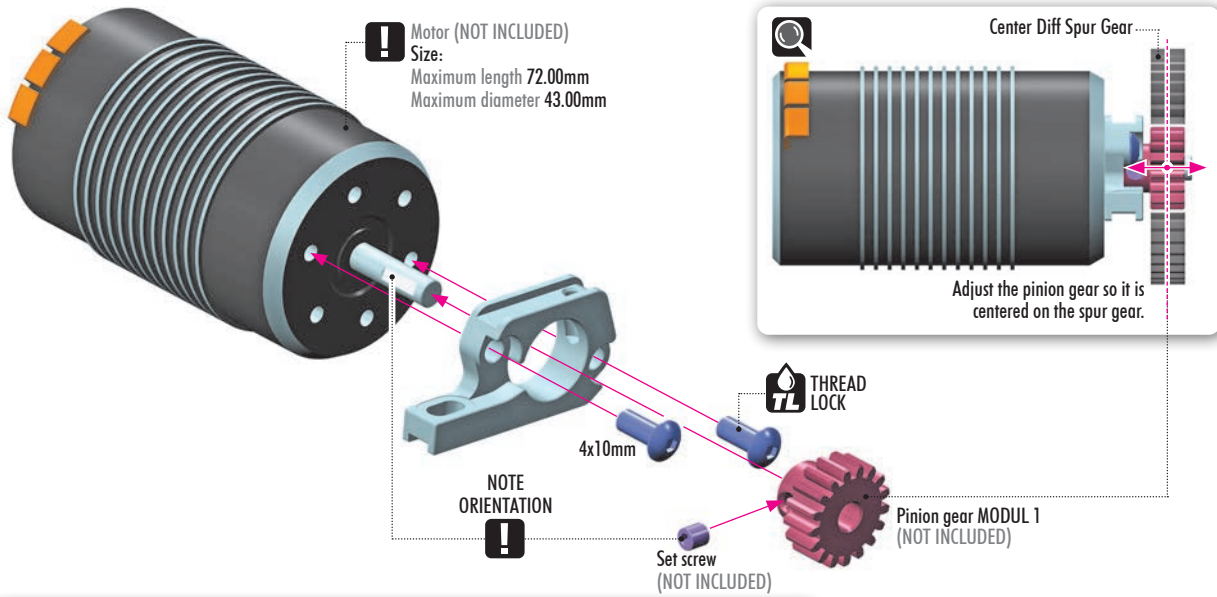
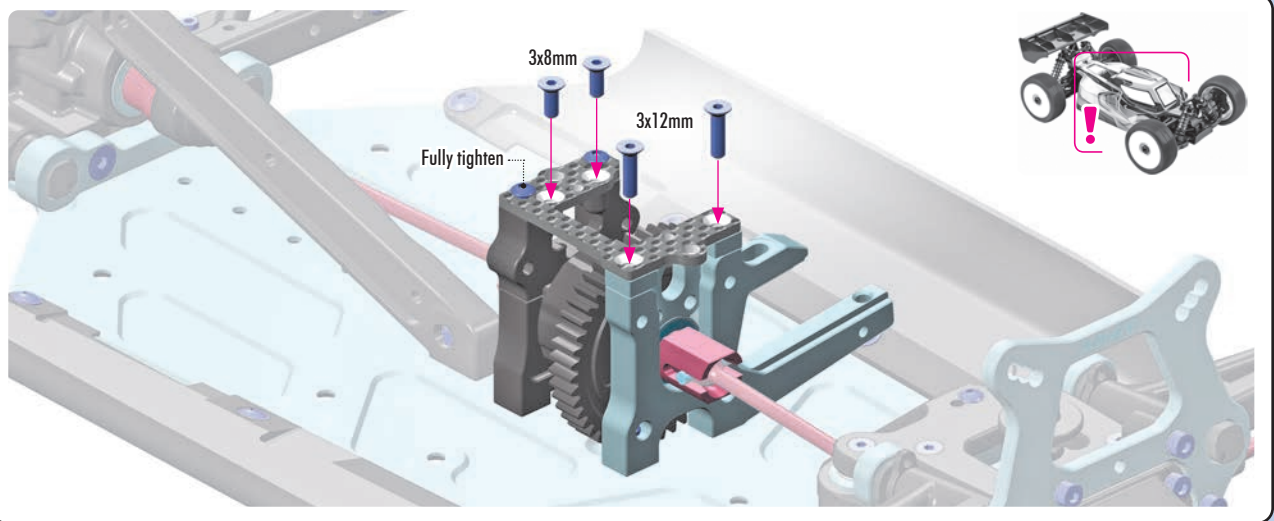

| OPTION     | ALL PINION GEAR (M1) | OPTION |
|------------|----------------------|--------|
|            | #355819 19T          | OPTION |
| WIDE (7mm) | #355820 20T          | OPTION |
|            | #355821 21T          | OPTION |
|            | #355822 22T          | OPTION |
|            | #355823 23T          | OPTION |
|            | #355824 24T          | OPTION |

| OPTION       | STEEL PINION GEAR (M1) | OPTION |
|--------------|------------------------|--------|
|              | #355712 12T            | OPTION |
| NARROW (5mm) | #355713 13T            | OPTION |
|              | #355714 14T            | OPTION |
|              | #355715 15T            | OPTION |
|              | #355716 16T            | OPTION |
|              | #355717 17T            | OPTION |
|              | #355718 18T            | OPTION |

| OPTION     | STEEL PINION GEAR (M1) | OPTION |
|------------|------------------------|--------|
|            | #294313 13T            | OPTION |
| WIDE (7mm) | #294314 14T            | OPTION |
|            | #294315 15T            | OPTION |
|            | #294316 16T            | OPTION |
|            | #294317 17T            | OPTION |
|            | #294318 18T            | OPTION |

**!** \*Suggested to use only with COMPOSITE center diff spur gear.

**GEAR RATIO** Final Drive Ratio  
 $(46 : X) \times 3.54 = FDR$   
(Spur) (Pinion) (IGR)

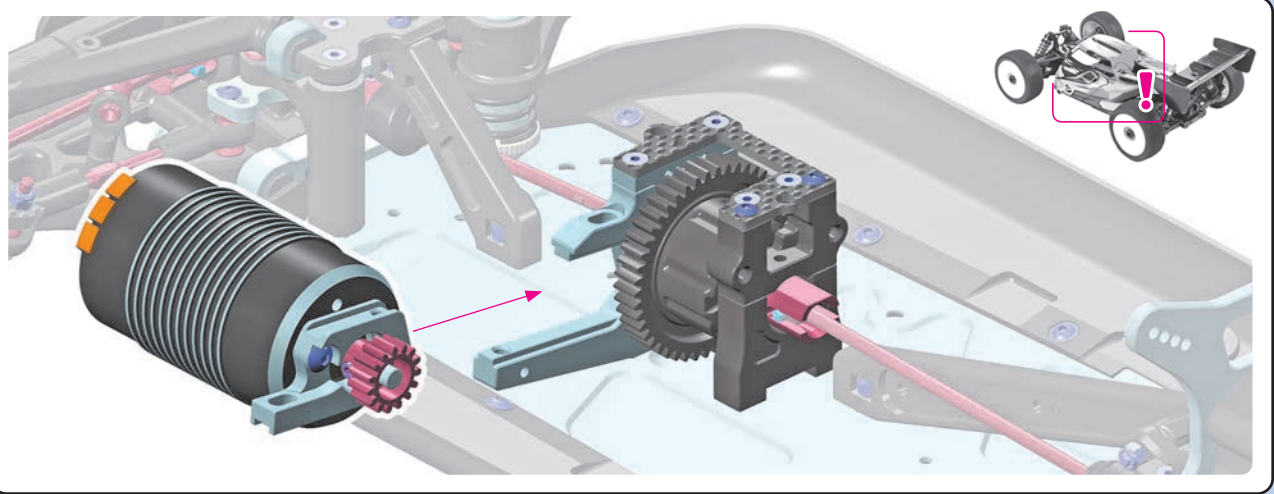

# 8. CENTER DIFF & BRAKE



2x 902412  
SH M4x12

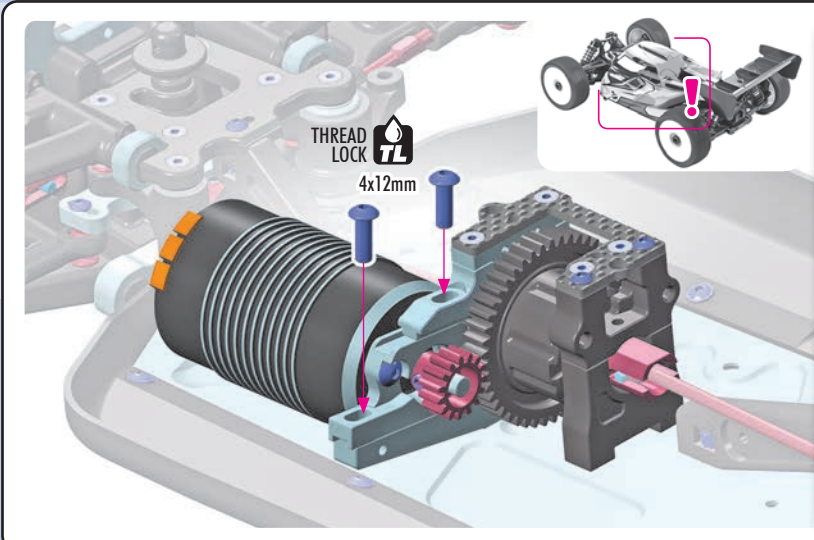

### GEAR MESH ADJUSTMENT



Adjust gear mesh so there is minimal play between the gears.

**TOO TIGHT** gear mesh will put excessive strain on all parts and damage the parts.

**TOO LOOSE** gear mesh may result in stripped gears.

### XB8E MOTOR COOLING (NOT INCLUDED)

OPTION

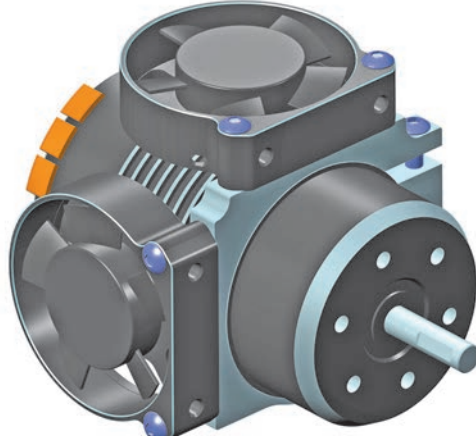

|  |  |   |  |
|--|--|---|--|
| <p>#293190<br/>ALU MULTI-FAN MOUNT FOR 42mm MOTOR</p> <p>OPTION</p>  <p>3x14mm INCLUDED</p> | <p>#293104<br/>HUDY ALU RC FAN 40mm - BOTTOM/SIDE MOUNT 2 HOLE</p> <p>OPTION</p>  | <p>#293111<br/>HUDY BRUSHLESS RC FAN 40mm WITH EXTERNAL SOLDERING TABS</p> <p>OPTION</p>  | <p>#293113<br/>HUDY BRUSHLESS RC FAN 40mm WITH INTERNAL SOLDERING TABS</p> <p>OPTION</p>  |
|--|--|---|--|



4x 903310  
SFH M3x10

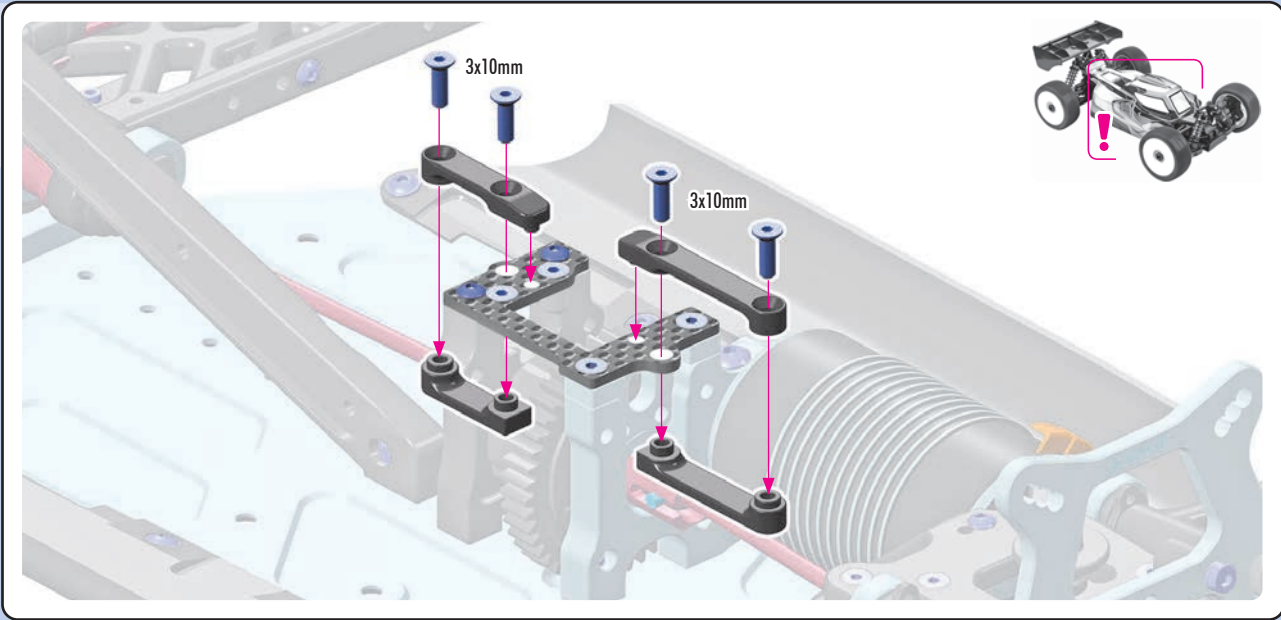

# 10. ELECTRONICS



#352670-G  
SERVO BALL JOINT 5.8mm - GRAPHITE (4)  
OPTION

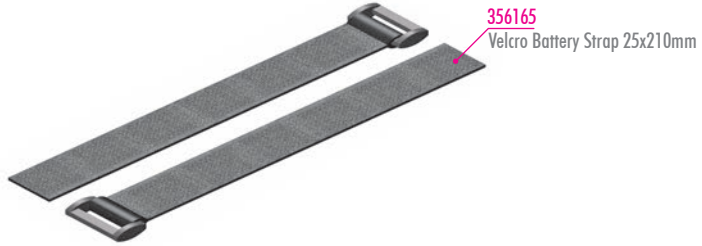

356165

Velcro Battery Strap 25x210mm

ALTERNATIVE 2  
2x LiPo Mid Size Pack  
(NOT INCLUDED)

ALTERNATIVE 1  
2x LiPo Short Size Pack  
(NOT INCLUDED)

Servo Screw  
(NOT INCLUDED)

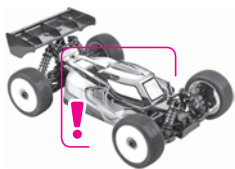
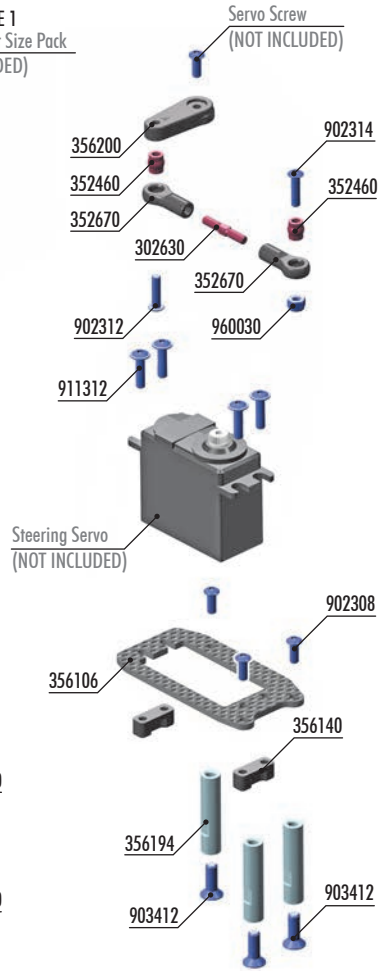
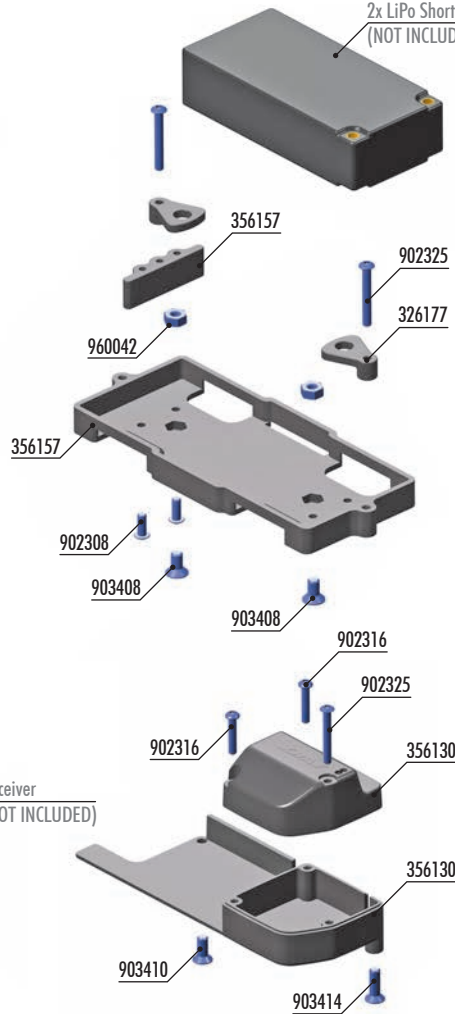
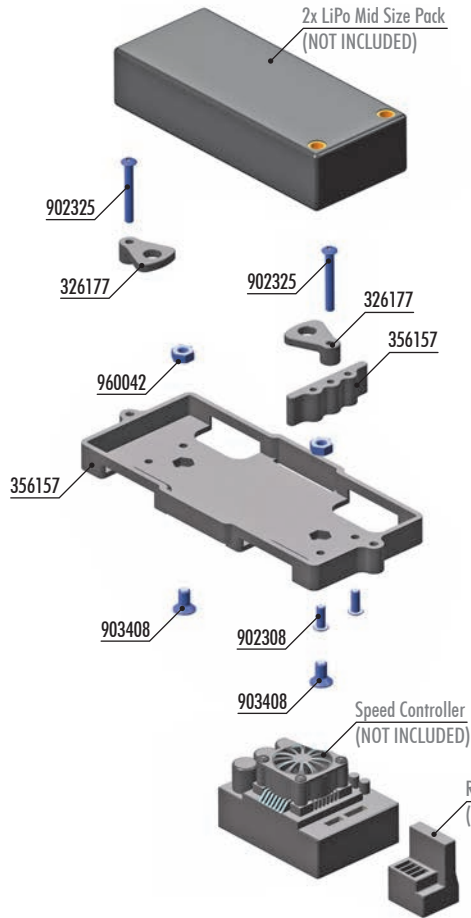

BAG

10

BAG 09 is NOT existing and NOT included in XB8E kit.

|        |   |
|--------|---|
| 302630 | ADJ. TURNBUCKLE L/R 20mm - HUDY SPRING STEEL™ (2)           |
| 326177 | COMPOSITE BATTERY CLAMP (2)                                 |
| 352460 | PIVOT BALL 5.8 (10)   |
| 352670 | SERVO BALL JOINT 5.8mm (4)                                  |
| 356106 | CARBON SERVO MOUNT - NARROW & LOWER BATTERY LAYOUT          |
| 356130 | COMPOSITE ONE-PIECE SPEEDO PLATE & RECEIVER BOX - V2        |
| 356140 | COMPOSITE SERVO MOUNT - SMALL (2)                           |
| 356157 | COMPOSITE BATTERY BOX FOR NARROW & LOWER BATTERY LAYOUT (2) |
| 356194 | ALU MOUNT FOR RECEIVER BOX                                  |
| 356200 | BRAKE/THROTTLE ARMS & STEERING SERVO ARMS - SET             |
| 902308 | HEX SCREW SH M3x8 (10)                                      |
| 902312 | HEX SCREW SH M3x12 (10)                                     |

|        |                                  |
|--------|----------------------------------|
| 902314 | HEX SCREW SH M3x14 (10)          |
| 902316 | HEX SCREW SH M3x16 (10)          |
| 902325 | HEX SCREW SH M3x25 (10)          |
| 903408 | HEX SCREW SFH M4x8 (10)          |
| 903410 | HEX SCREW SFH M4x10 (10)         |
| 903412 | HEX SCREW SFH M4x12 (10)         |
| 903414 | HEX SCREW SFH M4x14 (10)         |
| 911312 | HEX SCREW FLANGED SHF M3x12 (10) |
| 960030 | NUT M3 (10)                      |
| 960042 | NUT M4 (10)                      |

356165 VELCRO BATTERY STRAP 25x210mm (2)

Numbers in parentheses ( ) refer to quantities when purchased separately.

# 10. RADIO CASE



1x 902312  
SH M3x12

RIGHT THREAD SIDE LEFT THREAD SIDE

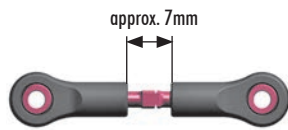
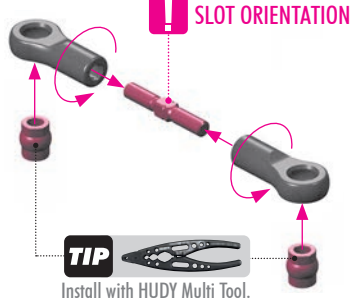

The length of the linkages varies according to the type of servo.

**!** Use appropriate servo arm:

Market servo horn  
**K** (23T) **H** (24T) **F** (25T)



### ALU SERVO HORNS

|         |     |        |
|---------|-----|--------|
| #293501 | 23T | OPTION |
| #293502 | 24T | OPTION |
| #293503 | 25T | OPTION |

### CLAMP ALU SERVO HORNS

|         |     |        |
|---------|-----|--------|
| #293407 | 23T | OPTION |
| #293408 | 24T | OPTION |
| #293409 | 25T | OPTION |



4x 911312  
SFH M3x12

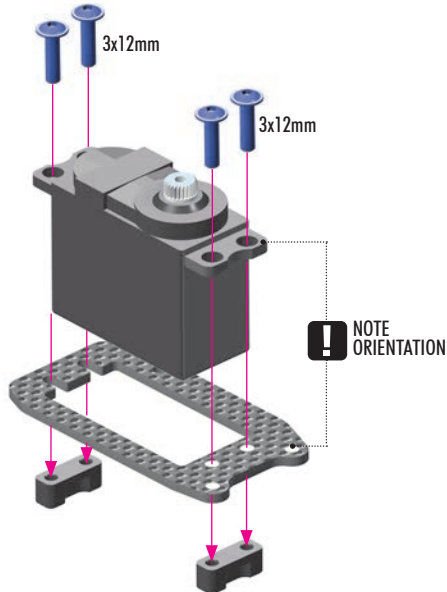

THREAD LOCK **TL** Servo Screw (NOT INCLUDED)

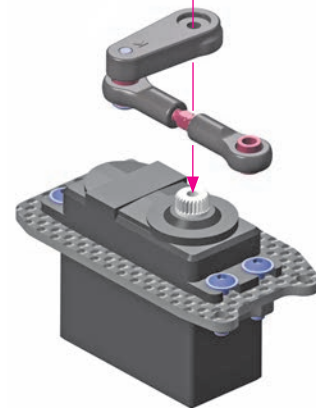

3x 903412  
SFH M4x12

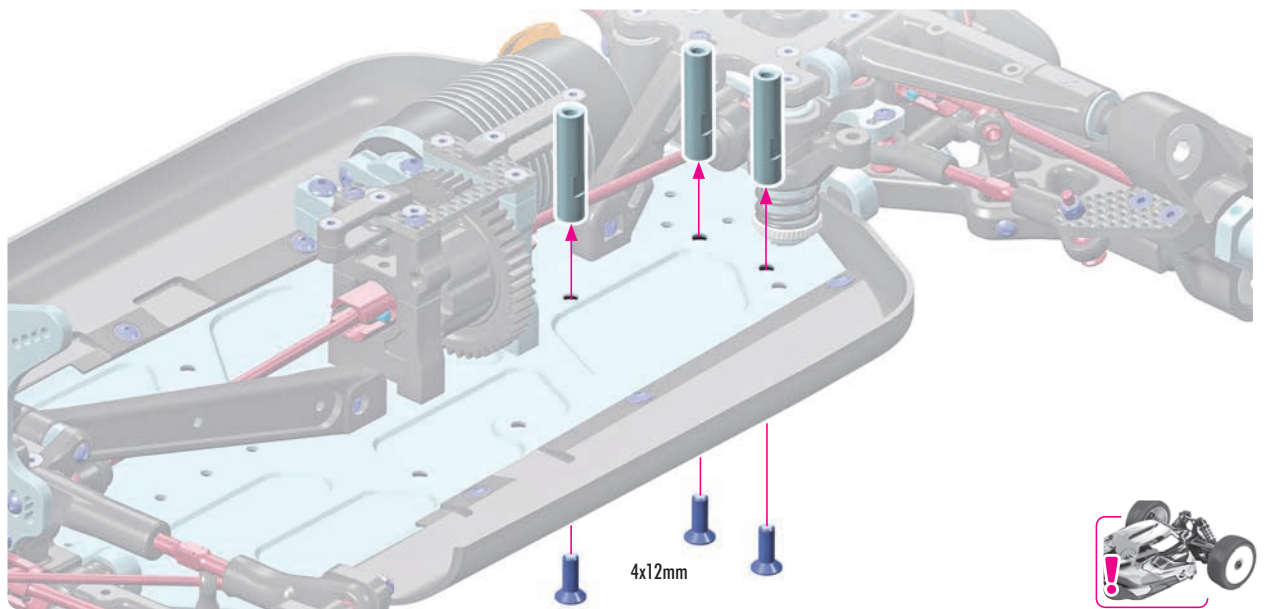



# 10. RADIO CASE



4x 903310  
SFH M3x10

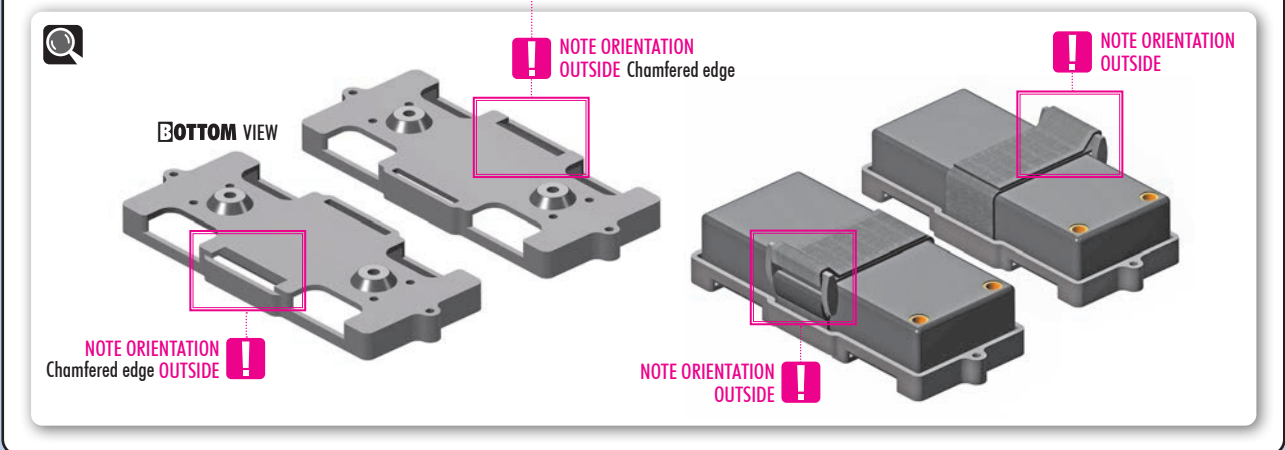
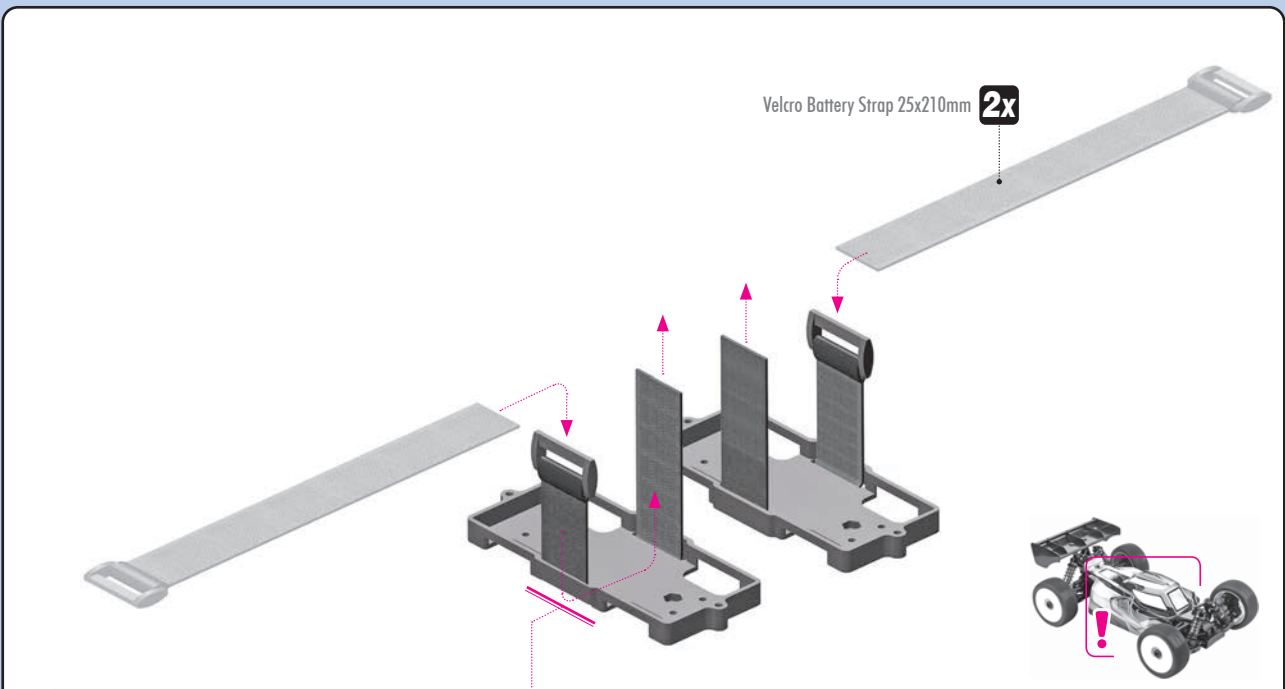
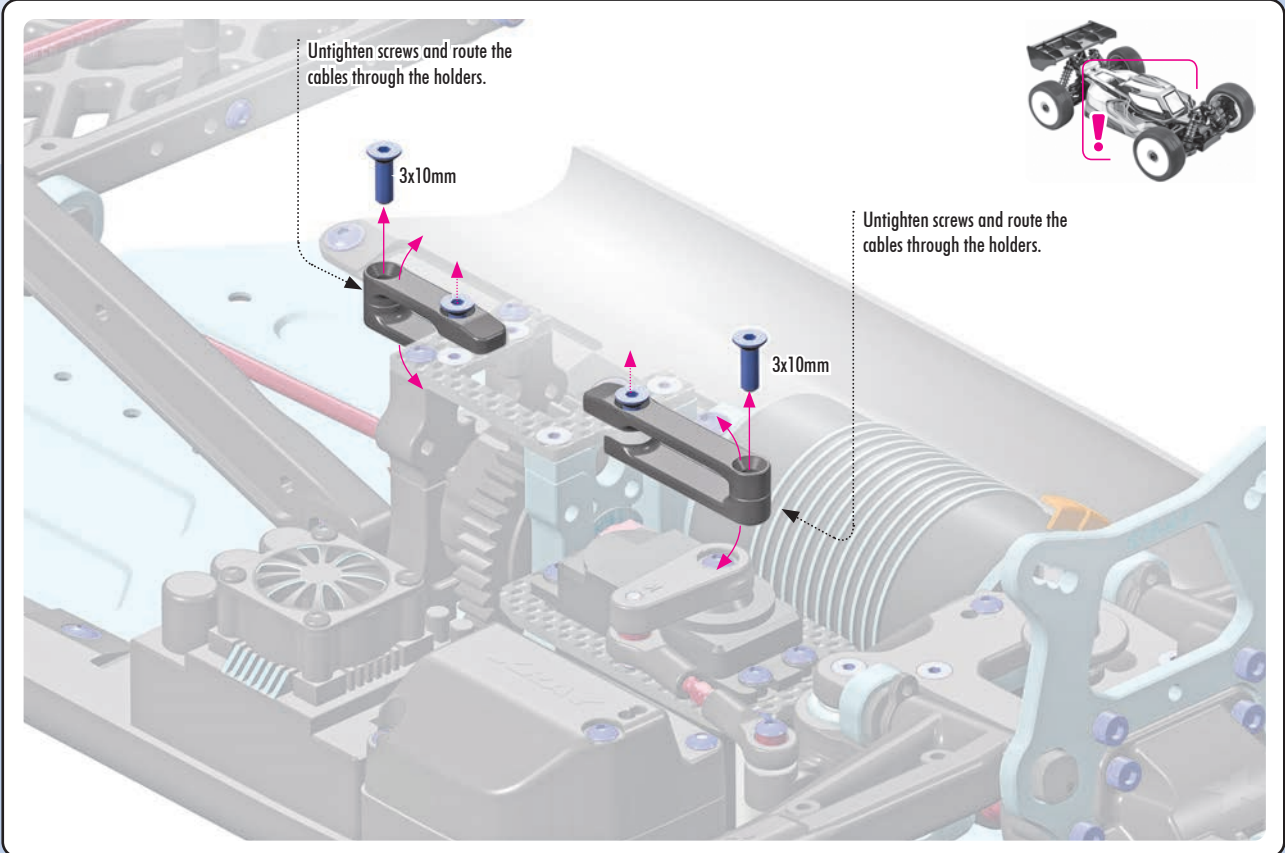

# 10. RADIO CASE

## ALTERNATIVE 1

CONFIGURATION **SHORT** BATTERY PACK  
SETTINGS WITH BALANCE POSITION

Adjustable battery holder setting  
in **FRONTWARD** position.

**INITIAL SETTING**

Adjustable battery holder setting  
in **REARWARD** position.

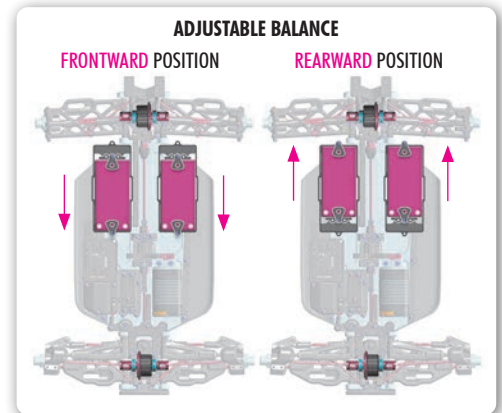
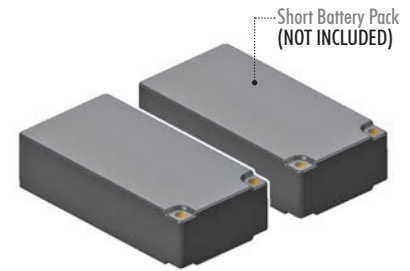
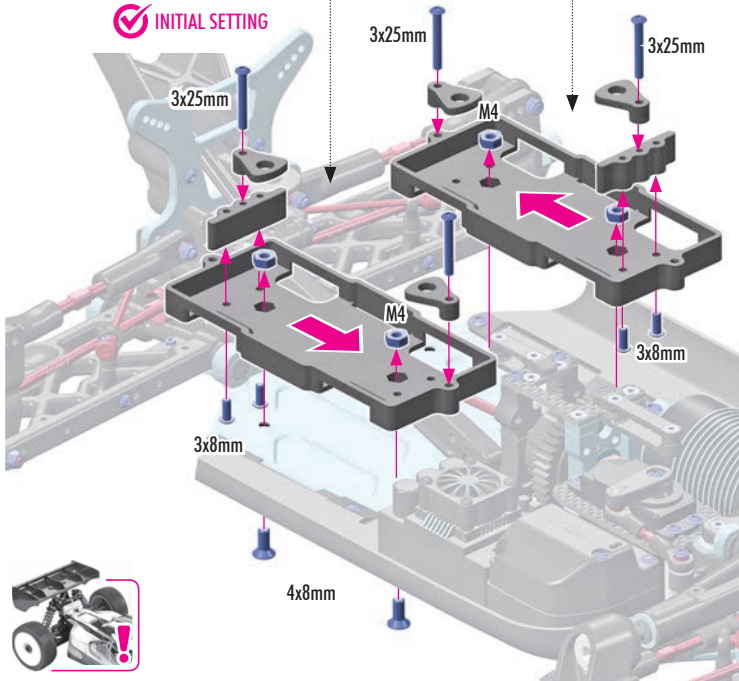

To ensure correct functioning of the battery holder, **DO NOT** overtighten the screw; the holder must be able to move.

ORIENTATION FOR  
**LOW BATTERY  
PACK**

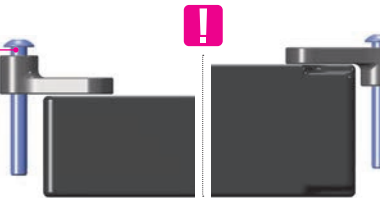

ORIENTATION FOR  
**STANDARD BATTERY  
PACK**

HEIGHT ADJUSTMENT  
1 turn = 0.5mm



## ALTERNATIVE 2

CONFIGURATION FOR **MID SIZE** BATTERY PACK

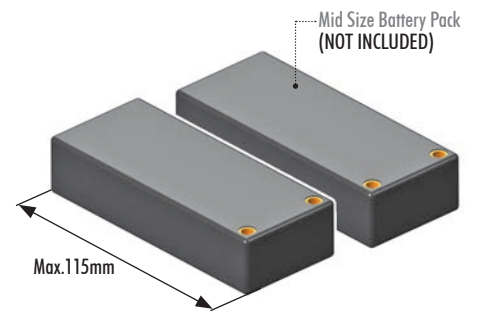
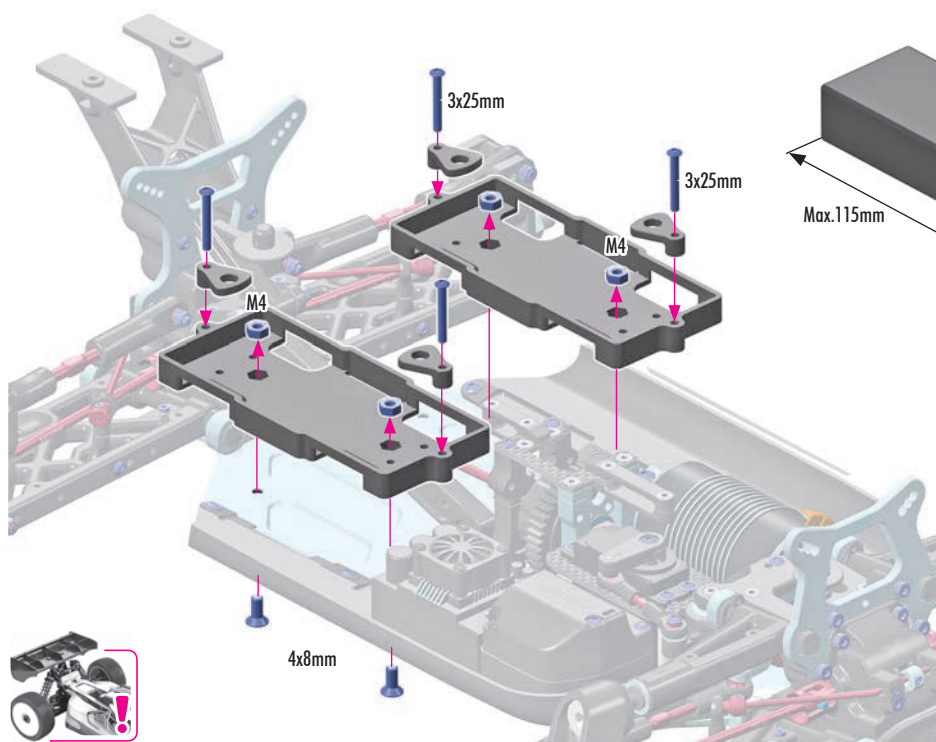

**STANDARD BALANCE**

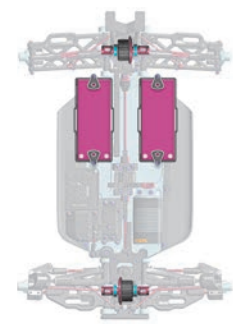

# 11. SHOCK ABSORBERS

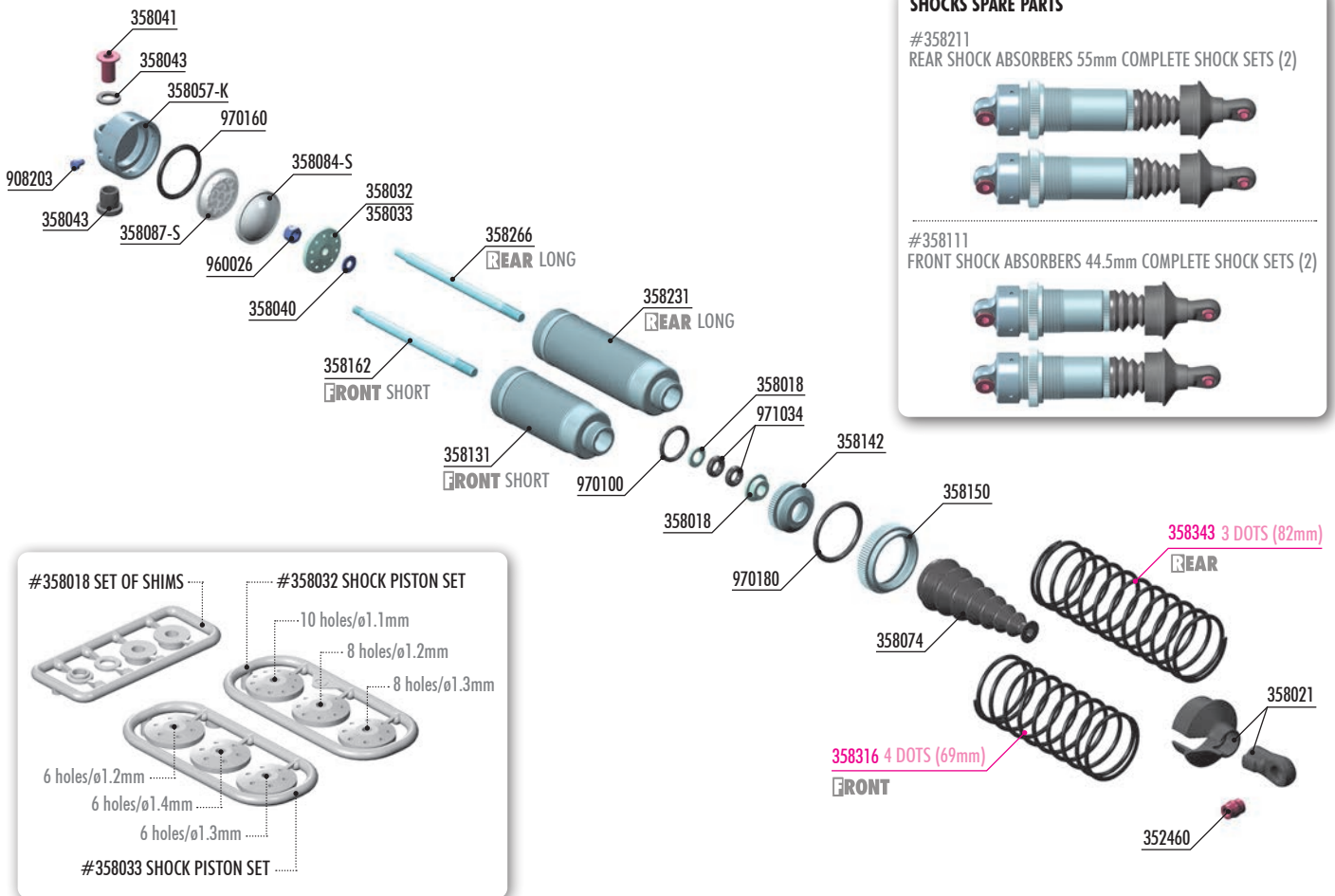

## SHOCKS SPARE PARTS

#358211  
REAR SHOCK ABSORBERS 55mm COMPLETE SHOCK SETS (2)

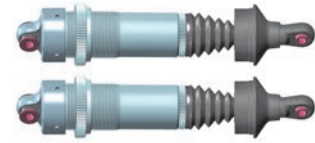

#358111  
FRONT SHOCK ABSORBERS 44.5mm COMPLETE SHOCK SETS (2)

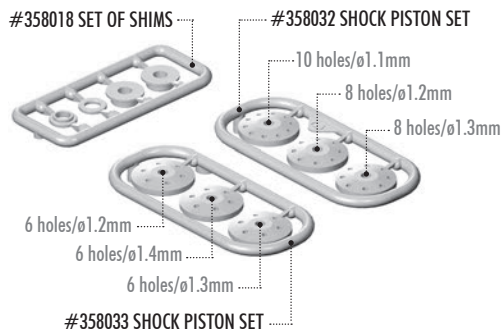
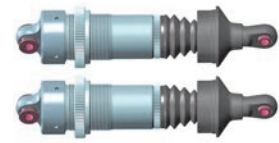

| SHOCK RUBBER MEMBRANE (4) |        |        |          |
|---------------------------|--------|--------|----------|
| #358084-S                 | RIBBED | SOFT   | INCLUDED |
| #358087-S                 | CELL   | SOFT   | INCLUDED |
| #358087-M                 | CELL   | MEDIUM | OPTION   |

| SHOCK SPRINGS |  |     |        |
|---------------|--|-----|--------|
| #358027       | PISTON 5-HOLE (1.5mm) & 2-HOLE (1.0mm) | (4) | OPTION |
| #358028       | PISTON 6-HOLE (1.3mm) & 2-HOLE (1.1mm) | (4) | OPTION |
| #308029       | PISTON 6-HOLE (1.4mm) & 2-HOLE (1.1mm) | (4) | OPTION |
| #358030       | PISTON 8-HOLE (1.2mm) & 2-HOLE (1.2mm) | (4) | OPTION |
| #358031       | PISTON 8-HOLE (1.3mm) & 2-HOLE (1.2mm) | (4) | OPTION |

| SHOCK SPRINGS |             |        |      |       |          |  |
|---------------|-------------|--------|------|-------|----------|--|
| #358315       | C=0.77-0.80 | 3 DOTS | 69mm | FRONT | OPTION   |  |
| #358316       | C=0.80-0.83 | 4 DOTS | 69mm | FRONT | INCLUDED |  |
| #358317       | C=0.83-0.86 | 5 DOTS | 69mm | FRONT | OPTION   |  |
| #358342       | C=0.66-0.68 | 2 DOTS | 82mm | REAR  | OPTION   |  |
| #358343       | C=0.68-0.70 | 3 DOTS | 82mm | REAR  | INCLUDED |  |
| #358344       | C=0.70-0.73 | 4 DOTS | 82mm | REAR  | OPTION   |  |
| #358334       | C=0.66-0.68 | 2 DOTS | 85mm | REAR  | OPTION   |  |
| #358335       | C=0.68-0.70 | 3 DOTS | 85mm | REAR  | OPTION   |  |



## BAGS

- 352460 PIVOT BALL 5.8 - V3 (10)
- 358018 COMPOSITE SET OF SHIMS FOR SHOCKS - V2 (2)
- 358021 COMPOSITE SHOCK PARTS WITH KEYED BALL JOINTS
- 358032 SHOCK PISTON SET 8-HOLE (1.2; 1.3) 10-H. (1.1mm) - DELRIN - V3
- 358033 COMPOSITE SHOCK 6-HOLE PISTON SET (1.2; 1.3; 1.4mm) - DELRIN - V3
- 358040 HARDENED SHOCK SHIMS (4)
- 358041 STEEL SHOCK BUSHING (2)
- 358043 COMPOSITE SHOCK BUSHING & SHIM (2+2)
- 358057-K MULTI ADJ. 3-IN-1 ALU SHOCK CAP - SWISS 7075 T6 (2)
- 358074 FOLDING SHOCK BOOT (4)
- 358084-S SHOCK RUBBER MEMBRANE BOTTOM RIBBED - SOFT (4)
- 358087-S SHOCK RUBBER MEMBRANE CELL - SOFT (4)
- 358111 FRONT SHOCK ABSORBERS 44.5mm - COMPLETE SET (2)
- 358131 ALU FRONT SHOCK BODY 44.5mm - SWISS 7075 T6 (2)
- 358142 ALU SHOCK BODY NUT FOR SHOCK BOOT (2)
- 358150 ALU SHOCK BODY ADJ. NUT (2)
- 358162 FRONT SHOCK SHAFT 56mm (2)
- 358211 REAR SHOCK ABSORBERS 55mm - COMPLETE SET (2)

- 358231 ALU REAR SHOCK BODY 55mm - SWISS 7075 T6 (2)
- 358266 REAR SHOCK SHAFT 66.5mm (2)
- 908203 HEX SCREW SOCKET HEAD CAP M2x3 (10)
- 960026 NUT M2.5 - SHORT (10)
- 970100 O-RING 10 x 1.5 (10)
- 970160 O-RING 16 x 2.0 (10)
- 970180 O-RING 18 x 1.8 (10)
- 971034 SILICONE O-RING 3.5x2 (10)

- 358316 XRAY FRONT SPRING 69mm - 4 DOTS (2)
- 358343 XRAY REAR SPRING 82mm - 3 DOTS (2)

Numbers in parentheses ( ) refer to quantities when purchased separately.

# 11. SHOCK ABSORBERS

4x 358040  
S 2.5x6x0.5

4x 960026  
N M2.5

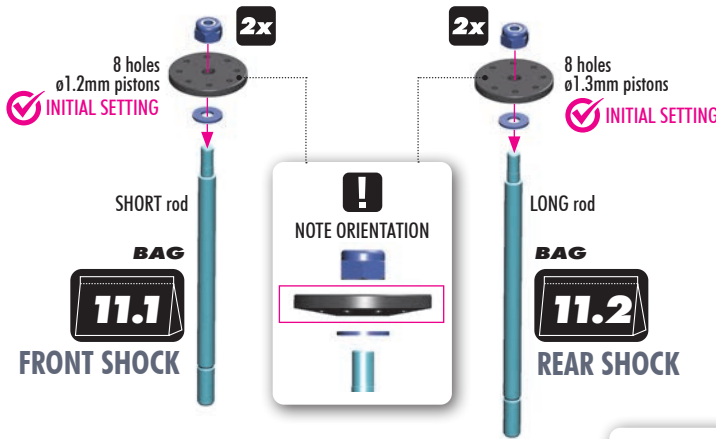

Install the piston with Professional Multi Tool (HUDY #183011).



- OPTION
- #358027 PISTON 5-HOLE (1.5mm) & 2-HOLE (1.0mm) (4)
  - #358028 PISTON 6-HOLE (1.3mm) & 2-HOLE (1.1mm) (4)
  - #308029 PISTON 6-HOLE (1.4mm) & 2-HOLE (1.1mm) (4)
  - #358030 PISTON 8-HOLE (1.2mm) & 2-HOLE (1.2mm) (4)
  - #358031 PISTON 8-HOLE (1.3mm) & 2-HOLE (1.2mm) (4)



### DO NOT OVERTIGHTEN

The self-locking nut is overtightened, causing distortion of the piston. This will negatively affect the free movement of the piston in the shock body.

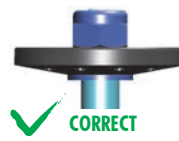

### TIGHTEN GENTLY

The self-locking nut is gently tightened. The piston remains undistorted and fits inside the shock body perfectly, ensuring smooth movement of the piston.

**SET-UP BOOK**  
SHOCK DAMPING  
SHOCK PISTONS

4x 970100  
O 10x1.5

8x 971034  
O 3.4x2

2x FRONT SHOCKS (SHORT)

2x REAR SHOCKS (LONG)

There are two different thickness shims, use them as shown. Use the same procedure when building both front and rear shocks.

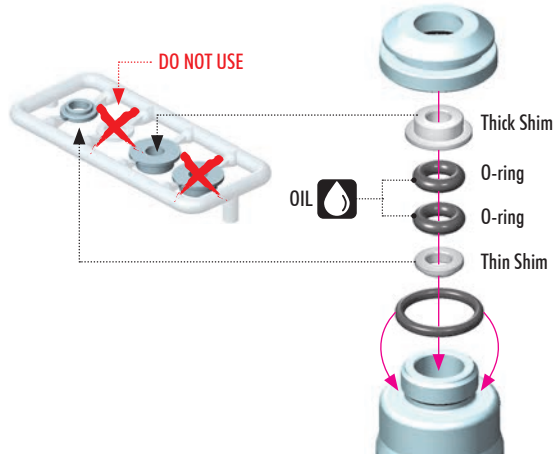

2x

FRONT SHOCKS

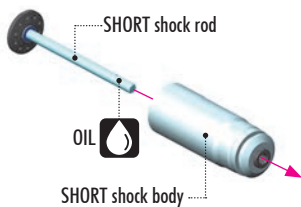

2x

REAR SHOCKS

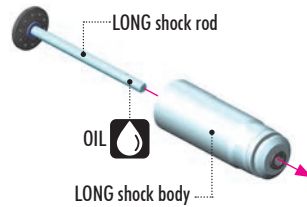

EXTREMELY IMPORTANT

DO NOT push the shock rod straight through the lower shock body assembly; O-ring damage may result.

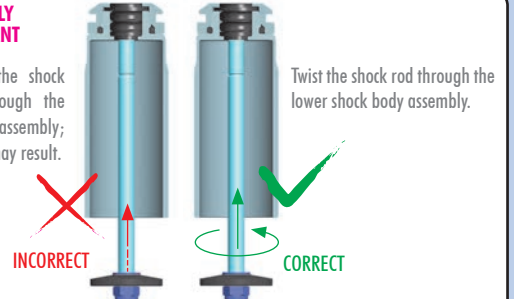

2x FRONT SHOCKS

2x REAR SHOCKS

4x 970180  
O 18x1.8

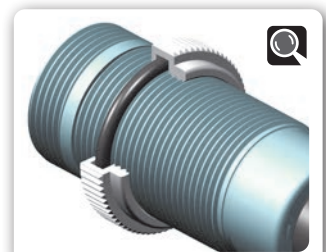
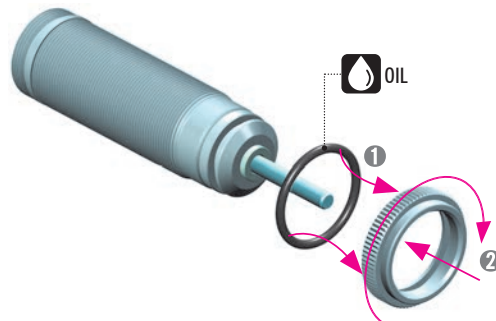

# 11. SHOCK ABSORBERS

**2x** FRONT SHOCKS

**2x** REAR SHOCKS

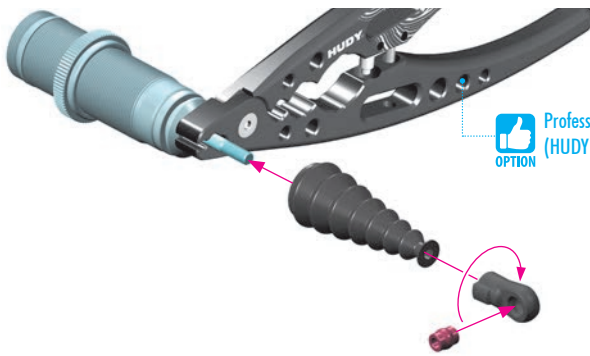

Professional Multi-Tool  
(HUDY #183011).  
OPTION

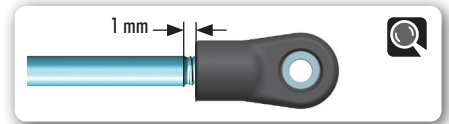
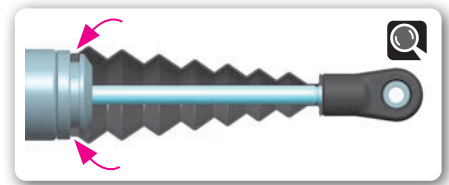

## SHOCK TYPE: CELL MEMBRANE

for LOW GRIP

Follow the steps below to set the shock rebound to the default setting of 0%.



1 Extend the shock shaft completely. Fill the shock body with the shock oil.



2 Move the shock shaft up and down a few times to release the air bubbles trapped beneath the piston.



3 Orient the filled shock vertically for several minutes with the shock shaft fully extended. The remaining air bubbles will release.

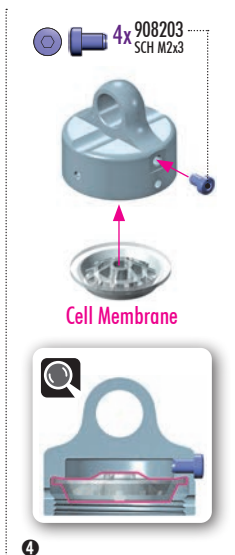

4 Install the CELL shock membrane and screw into the groove in the upper shock cap.

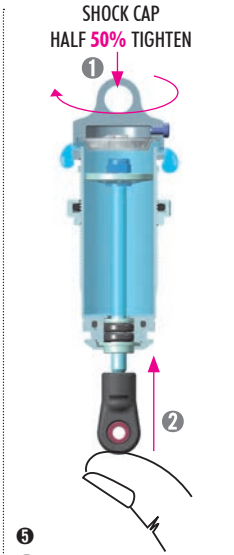

5 Gently place the shock cap assembly onto the filled shock body. 2 Slowly compress the shock shaft towards the top of the shock body and hold in this position. Excess oil will be expelled from the shock.



6 While still holding the shock shaft in position, fully tighten the shock cap.

## SHOCK TYPE: RIBBED MEMBRANE

for BUMPY - HIGH GRIP

Follow the steps below to set the shock rebound to the default setting of 0%.



1 Extend the shock shaft completely. Fill the shock body with the shock oil.



2 Move the shock shaft up and down a few times to release the air bubbles trapped beneath the piston.



3 Orient the filled shock vertically for several minutes with the shock shaft fully extended. The remaining air bubbles will release.

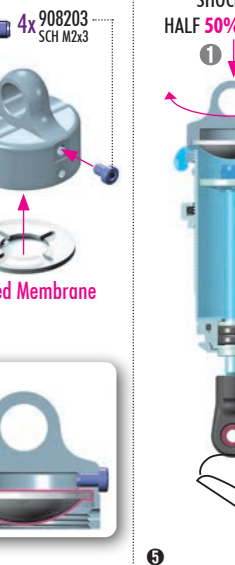

4 Install the RIBBED shock membrane and screw into the groove in the upper shock cap.

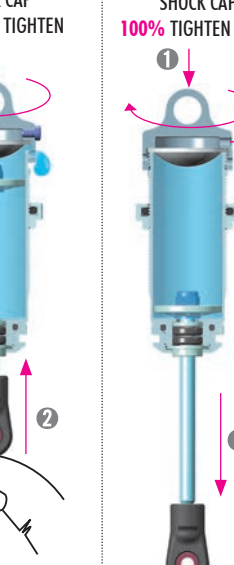

5 Gently place the shock cap assembly onto the filled shock body. 2 Slowly compress the shock shaft towards the top of the shock body and hold in this position. Excess oil will be expelled from the shock.



6 Fully tighten the shock cap. 2 Loosen the cap screw. 3 Extend the shock shaft. 4 Slowly compress shock shaft completely into shock body, forcing air from the cap. 5 While still holding the shock shaft in compressed position, re-tighten screw to seal cap.

# 11. SHOCK ABSORBERS

SHOCK TYPE: **EMULSION**

for DEFAULT STANDARD

Follow the steps below to set the shock rebound to the default setting of 0%.

**OIL** Oil level after filling  
**CORRECT FILLING**

**INCORRECT FILLING**

**FRONT (SHORT)**  
Oil 600cSt

**REAR (LONG)**  
Oil 550cSt

**1**

Extend the shock shaft completely. Fill the shock body with the shock oil.

**2**

Move the shock shaft up and down a few times to release the air bubbles trapped beneath the piston.

3~5x  
UP & DOWN

**3**

Orient the filled shock vertically for several minutes with the shock shaft fully extended. The remaining air bubbles will release.

**4**

4x 970160  
0 16x2

O-ring

Install o-ring in the cap.

**5**

Fill the shock cap with oil up to the o-ring.

**6**

**SHOCK CAP**  
**100% TIGHTEN FULLY**

Carefully place the shock cap onto the oil filled shock body and tighten the cap. Some oil may spill from the shock during this process.

**7**

Slowly compress the shock shaft completely into the shock body. Excess oil will flow through the hole in the shock cap.

GENTLY PUSH

**8**

With the shock shaft still compressed, tighten the screw.

4x 908203  
SCH M2x3

**9**

6x push the shaft up and down.

6x  
UP & DOWN

**10**

Slowly push the shock shaft completely into the shock body. Excess oil will flow through the hole in the shock cap.

**11**

Gently push the shock shaft completely into the shock body. Excess oil will flow through the hole in the shock cap.

GENTLY PUSH

**12**

Tighten the screw.

**2x REAR SHOCKS**

LONG rear shock

LONG spring

**REAR shock PRELOAD**

approx. 4-5mm

**2x FRONT SHOCKS**

SHORT front shock

SHORT spring

**FRONT shock PRELOAD**

approx. 4-5mm

**IMPORTANT!**

This setting affects the front and rear ride height of the car. Check the ride height once the car is fully assembled and ready to run.

**IMPORTANT!**

Both front shocks and rear shocks must be the same overall length.

**IMPORTANT!**

**FRONT & REAR SHOCKS**

# 12. FINAL ASSEMBLY

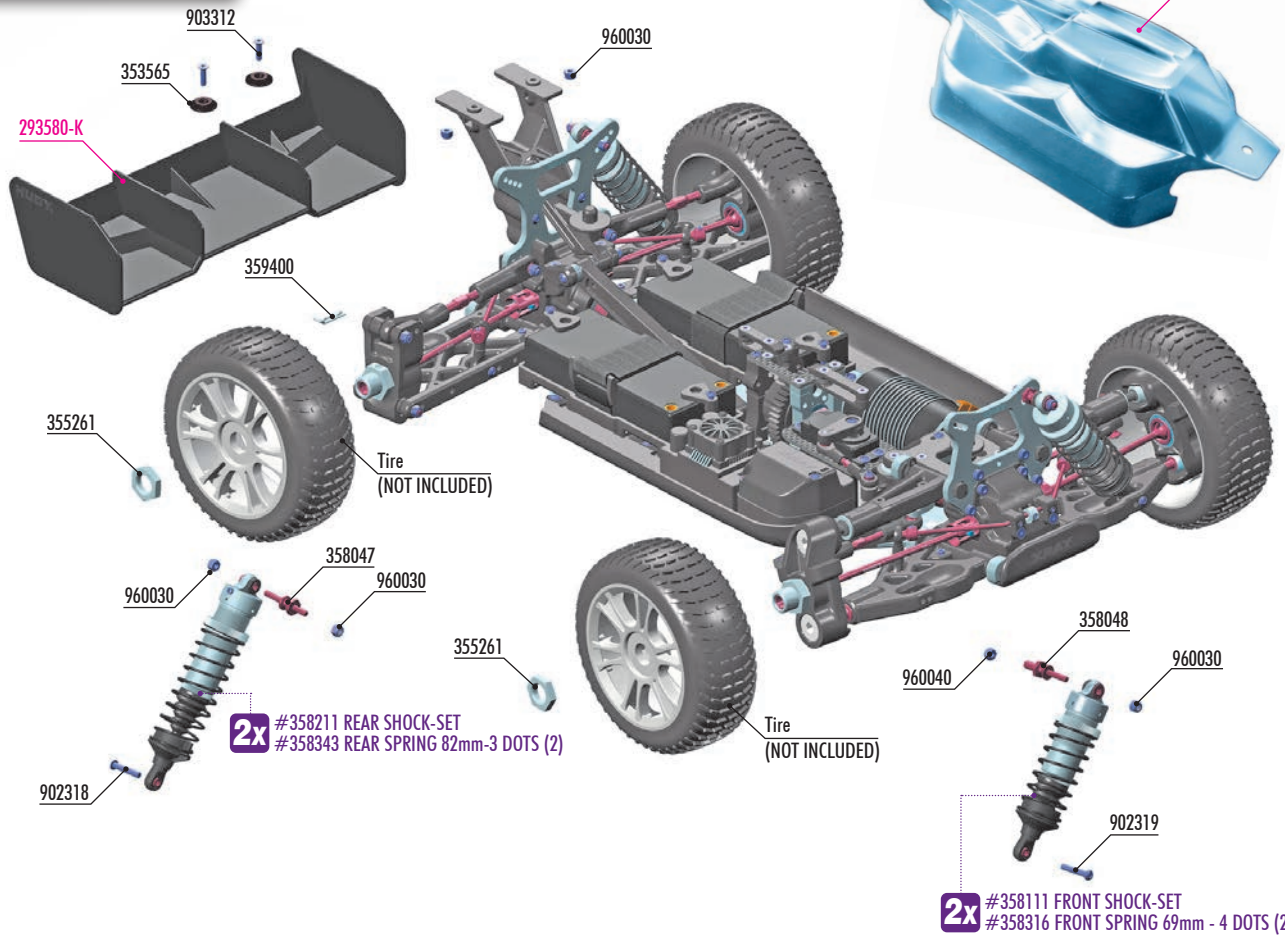

| OPTION    | WINGS  |          |
|-----------|--------|----------|
| #293580-K | BLACK  | INCLUDED |
| #293580   | WHITE  | OPTION   |
| #293580-G | GREEN  | OPTION   |
| #293580-O | ORANGE | OPTION   |
| #293580-Y | YELLOW | OPTION   |



#353512  
OPTION LEXAN® REAR WING 1-8 OFF-ROAD



#353590  
OPTION LEXAN® FRONT WING GRIPPER



| OPTION  | WHEEL NUTS     |          |
|---------|----------------|----------|
| #355261 | OPEN RIBBED    | INCLUDED |
| #293560 | COVERED RIBBED | OPTION   |
| #355265 | COVERED RIBBED | OPTION   |

| OPTION    | HUDY REAR WING SHIM |        |
|-----------|---------------------|--------|
| #293561   | SILVER              | OPTION |
| #293561-O | ORANGE              | OPTION |
| #293561-K | BLACK               | OPTION |
| #353561   | SILVER              | OPTION |

| OPTION  | XB8 BODIES         |          |
|---------|--------------------|----------|
| #359713 | "EAZY"             | INCLUDED |
| #359714 | "EAZY" LIGHTWEIGHT | OPTION   |

#358048-T  
OPTION TITANIUM M4/M3 UPPER SHOCK MOUNT STAND OFF WITH HEX (2)



#358047-T  
OPTION TITANIUM M3/M3 UPPER SHOCK MOUNT STAND OFF WITH HEX (2)



BAG





12

- 353565 COMPOSITE REAR WING SHIM - BLACK (2)
- 355261 WHEEL NUT - RIBBED - HARD COATED (2)
- 358047 STEEL M3/M3 UPPER SHOCK MOUNT STAND OFF WITH HEX (2)
- 358048 STEEL M4/M3 UPPER SHOCK MOUNT STAND OFF WITH HEX (2)
- 359400 BODY CLIP (10)
- 902318 HEX SCREW SH M3x18 (10)
- 902319 HEX SCREW SH M3x18 - LEFT THREAD (10)
- 903312 HEX SCREW SFH M3x12 (10)

- 960030 NUT M3 (10)
- 960040 NUT M4 (10)
- 293580-K HUDY 1/8 OFF-ROAD STRIKE WING - BLACK
- 359713 XRAY XB8 / XB8E "EAZY" BODY
- 358111 FRONT SHOCK ABSORBERS 44.5mm - COMPLETE SET (2)
- 358211 REAR SHOCK ABSORBERS 55mm - COMPLETE SET (2)

Numbers in parentheses ( ) refer to quantities when purchased separately.

# 12. FINAL ASSEMBLY

-  902318 SH M3x18 1x
-  902319 SH M3x18 LEFT thread 1x
-  2x 960030 N M3
-  2x 960040 N M4

### FRONT SHOCKS (SHORT)

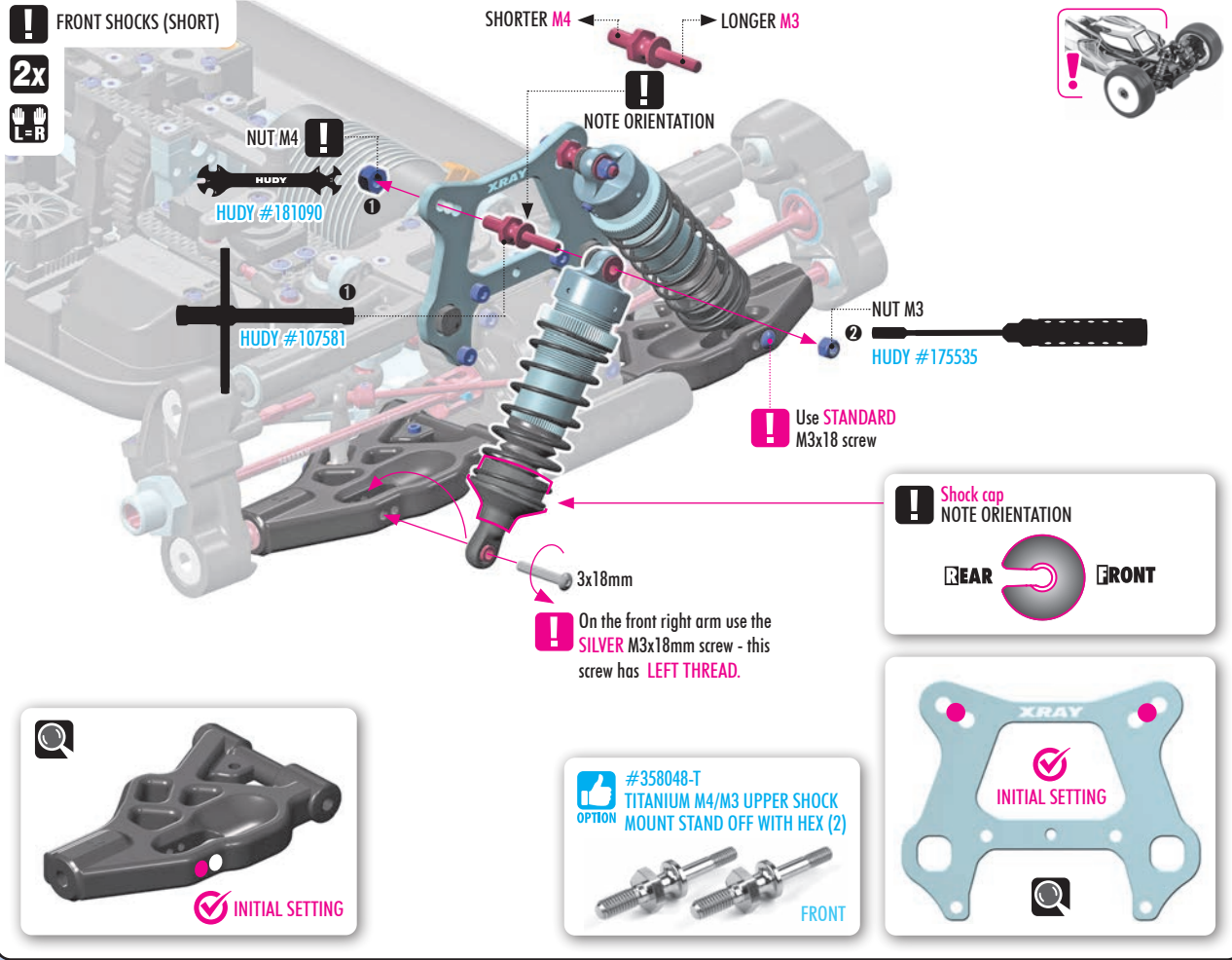

**2x** **L=R**

**! FRONT SHOCKS (SHORT)**

SHORTER M4 → LONGER M3

**! NOTE ORIENTATION**

NUT M4 **!**

HUDY #181090

HUDY #107581

NUT M3

HUDY #175535

**! Use STANDARD M3x18 screw**

Shock cap **! NOTE ORIENTATION**

REAR FRONT

3x18mm

**! On the front right arm use the SILVER M3x18mm screw - this screw has LEFT THREAD.**

**INITIAL SETTING**

**OPTION** #358048-T TITANIUM M4/M3 UPPER SHOCK MOUNT STAND OFF WITH HEX (2) FRONT

**SET-UP BOOK**  
SHOCK ABSORBERS

-  902318 M3x18 1x
-  902319 SH M3x18 LEFT thread 1x
-  4x 960030 N M3

### REAR SHOCKS (LONG)

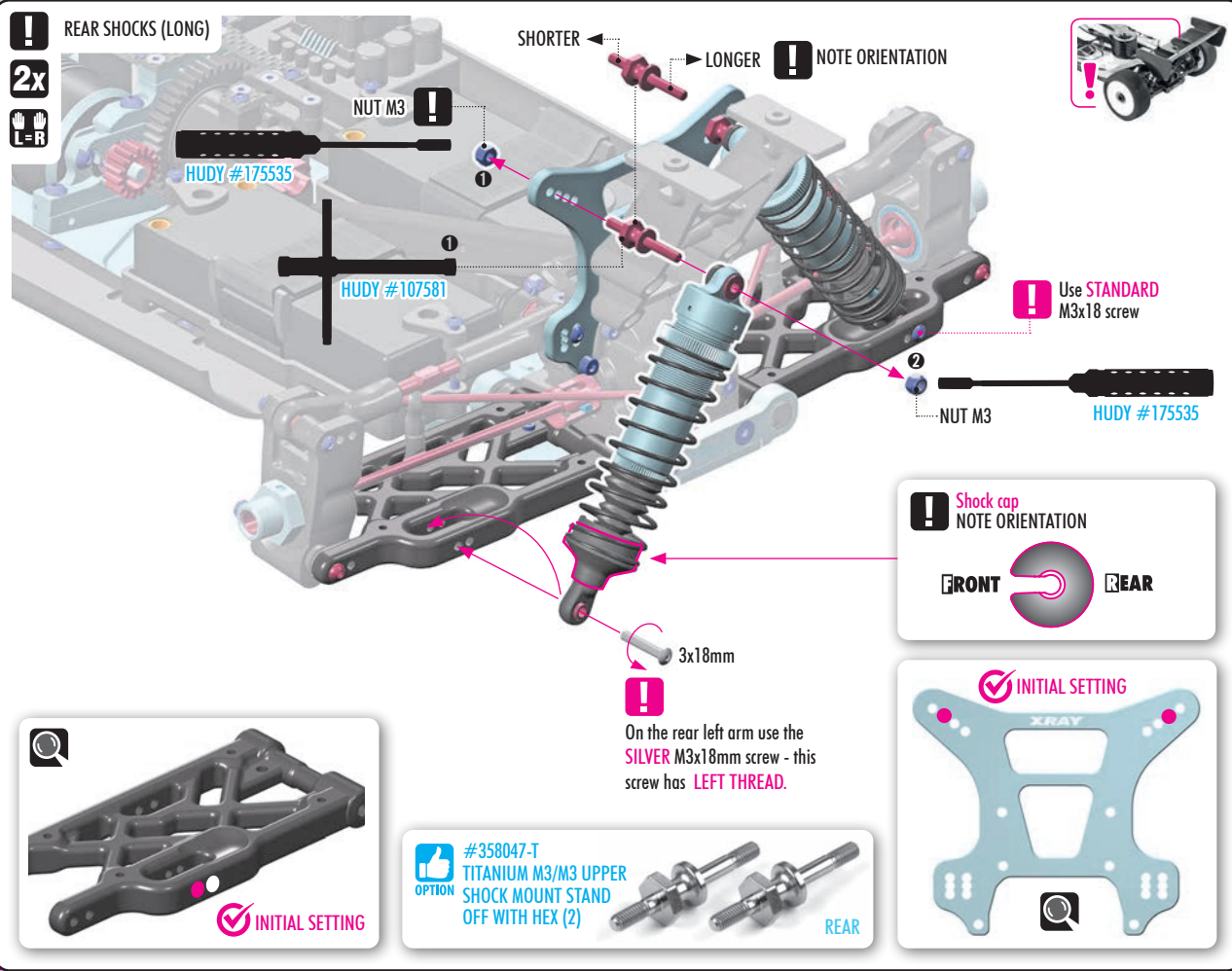

**2x** **L=R**

**! REAR SHOCKS (LONG)**

SHORTER → LONGER **! NOTE ORIENTATION**

NUT M3 **!**

HUDY #175535

HUDY #107581

NUT M3

HUDY #175535

**! Use STANDARD M3x18 screw**

Shock cap **! NOTE ORIENTATION**

FRONT REAR

3x18mm

**! On the rear left arm use the SILVER M3x18mm screw - this screw has LEFT THREAD.**

**INITIAL SETTING**

**OPTION** #358047-T TITANIUM M3/M3 UPPER SHOCK MOUNT STAND OFF WITH HEX (2) REAR

**SET-UP BOOK**  
SHOCK ABSORBERS

# 12. FINAL ASSEMBLY

## BODY PAINTING

- 1 Before cutting and making holes on the body, put the unpainted body on the chassis to confirm the mounting position and location for holes and cutouts.
- 2 Before painting, wash the inside of the body with mild detergent, and then rinse and dry thoroughly.
- 3 Mask all windows.
- 4 Apply paint masks as appropriate.
- 5 Paint the body using paints formulated for polycarbonate bodies.
- 6 When the paint is dry, remove the masking.
- 7 Carefully cut out the body using appropriate scissors or cutting tools.
- 8 When you have finished cutting, peel off the external protective films.



Body Reamer (HUDY #107602)

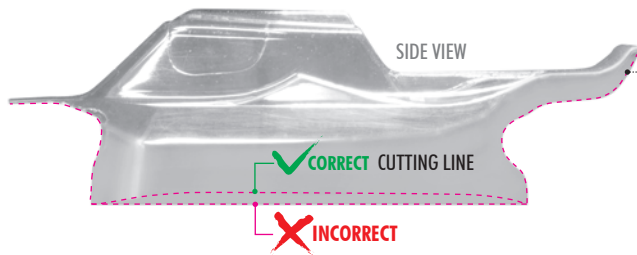

✓ CORRECT CUTTING LINE  
✗ INCORRECT

## BODY CUTTING

- 1 FRONT HOLE - mark and cut out the front hole first.
- 1 The premarked REAR HOLE fits older models of the XB8.
- 2 REAR HOLE - use this marked point as the center of the rear body hole (on the outer line of the premark).
- 3 Make the rear hole oval front-rear. This will help with clearance in case of chassis flex after a big crash to not tear up the hole.

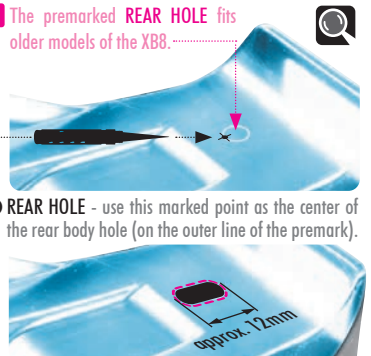

## TIP

To reinforce the body or to fix broken body use #106281 HUDY BODY FIX.



| XB8 BODIES |                    |          |
|------------|--------------------|----------|
| #359713    | "EAZY"             | INCLUDED |
| #359714    | "EAZY" LIGHTWEIGHT | OPTION   |

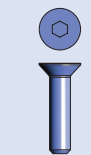

2x 903312 SFH M3x12



2x 960030 N M3



#353562 CARBON REAR WING SHIM



#107601 HUDY Reamer for Body 0-9mm + Cover - Small  
#107602 HUDY Reamer for Body 0-18mm + Cover - Large

Premarked holes to REDUCE DOWNFORCE.

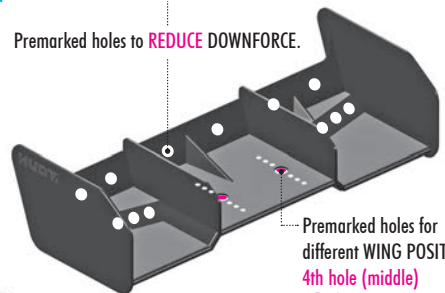
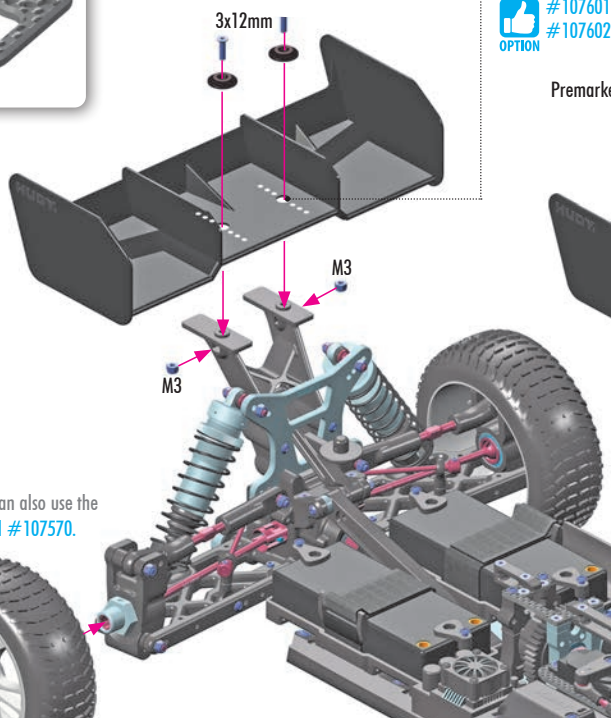

Premarked holes for different WING POSITIONS.  
4th hole (middle)  
✓ INITIAL SETTING

## TIP 4x

To tighten the setscrew you can also use the HUDY 17mm Wheel Nut Tool #107570.

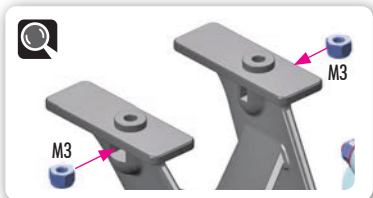

| WHEEL NUTS |                |          |
|------------|----------------|----------|
| #355261    | OPEN RIBBED    | INCLUDED |
| #293560    | COVERED RIBBED | OPTION   |
| #355265    | COVERED RIBBED | OPTION   |



#353512 LEXAN® REAR WING 1-8 OFF-ROAD



| WINGS     |        |          |
|-----------|--------|----------|
| #293580-K | BLACK  | INCLUDED |
| #293580   | WHITE  | OPTION   |
| #293580-G | GREEN  | OPTION   |
| #293580-O | ORANGE | OPTION   |
| #293580-Y | YELLOW | OPTION   |



If more than 104mm front droop is used, certain set-up configurations may result in the upper arm contacting the steering bellcranks.

This will have limited impact on handling, but material can be removed from the bottom of the upper arm to avoid contact with the steering assembly if using additional droop.

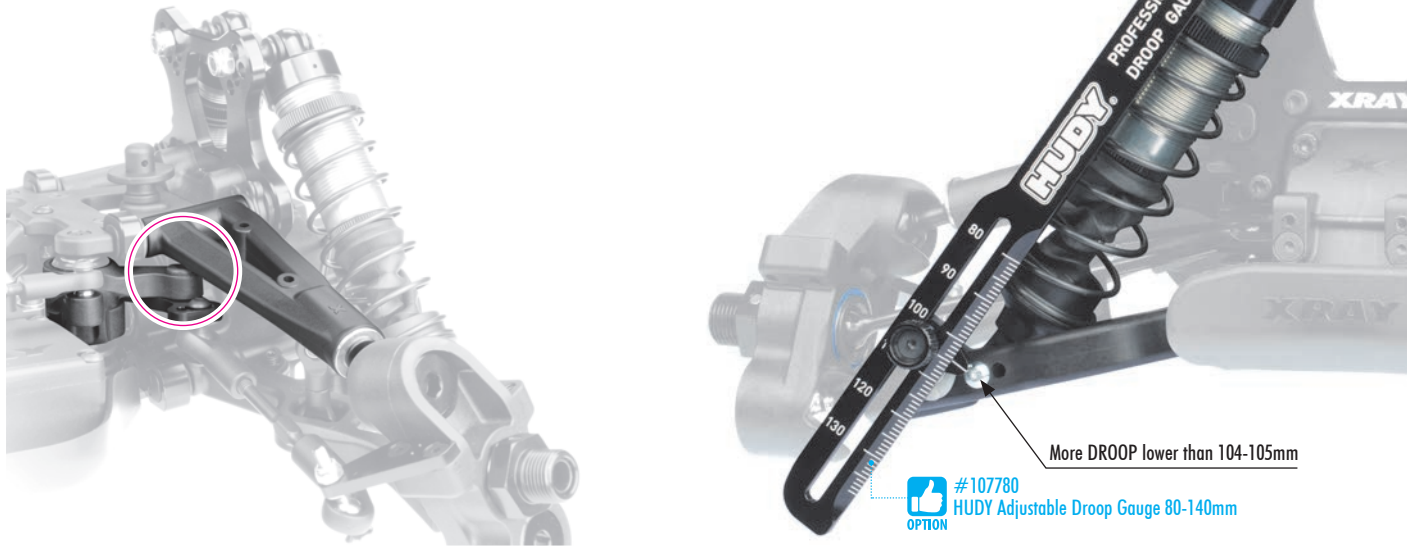

## DIFF MAINTENANCE

### REMOVING THE DIFFERENTIAL WHEN CAR IS ASSEMBLED

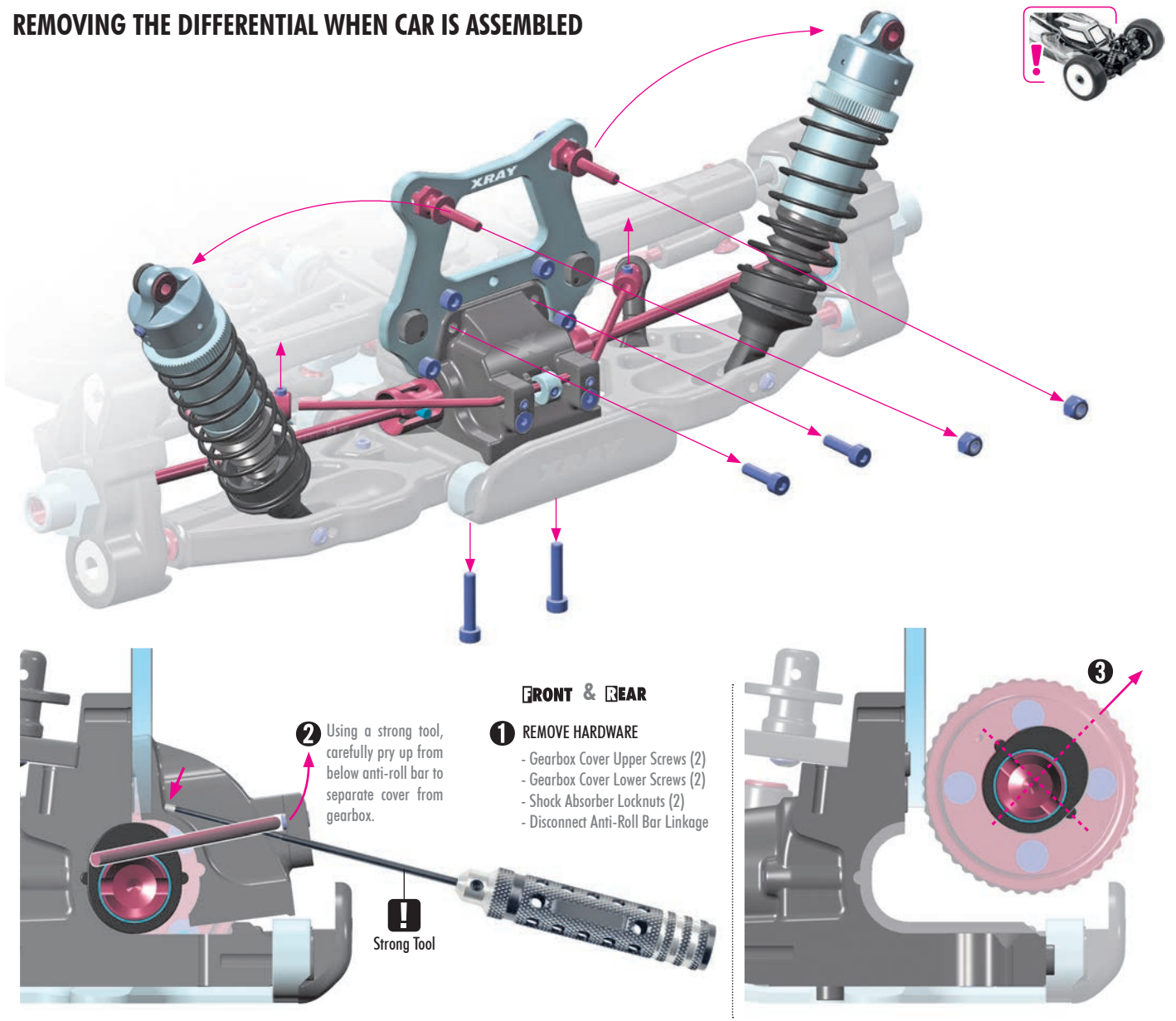

## INSTALLING THE DIFFERENTIAL WHEN CAR IS ASSEMBLED

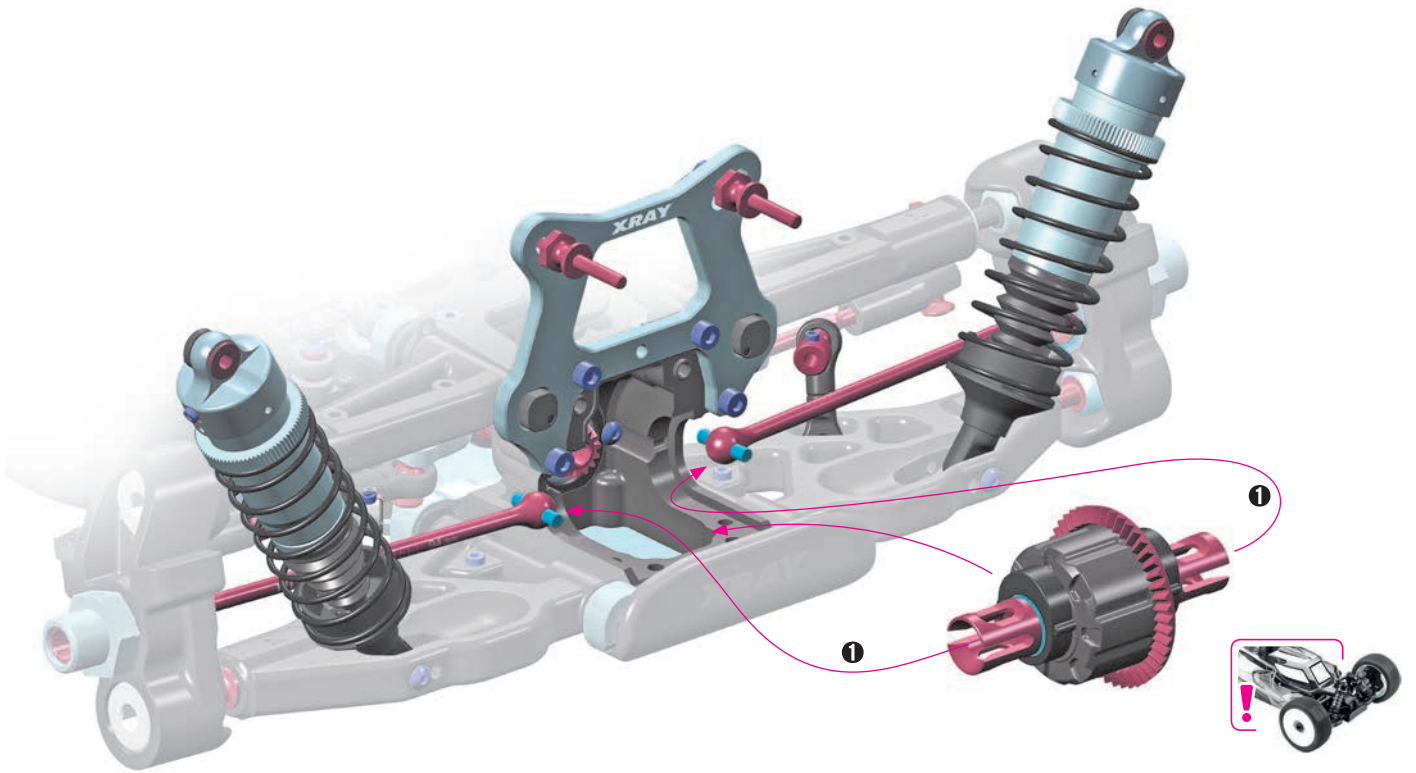

FRONT & REAR

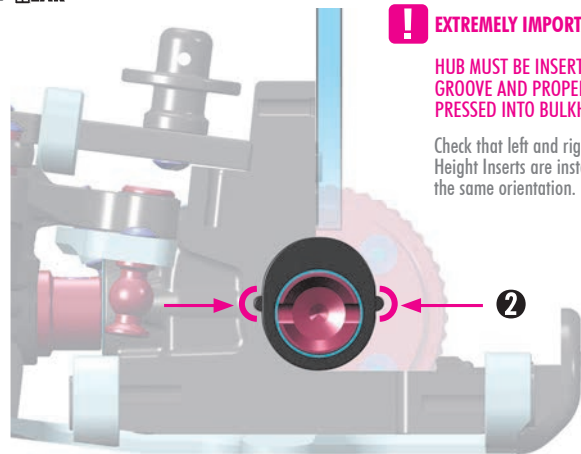

**!** EXTREMELY IMPORTANT

HUB MUST BE INSERTED IN GROOVE AND PROPERLY PRESSED INTO BULKHEAD.

Check that left and right Diff Height Inserts are installed in the same orientation.

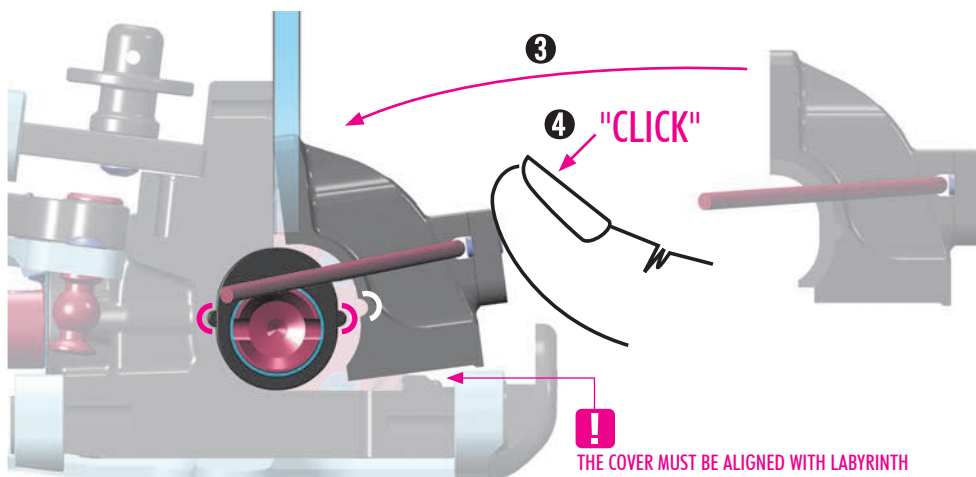

**!** THE COVER MUST BE ALIGNED WITH LABYRINTH GROOVE AND THEN PRESSED INTO PLACE

**5** RE-INSTALL HARDWARE

- Gearbox Cover Upper Screws (2)
- Gearbox Cover Lower Screws (2)
- Shock Absorber Locknuts (2)
- Reconnect Anti-Roll Bar Linkage

# XRAY TUNING PARTS

(NOT INCLUDED)



#350912

## XB8 Alu Rear Uprights - Multi-Adjustable - Set

- Increases stability
- Ultra strong & durable
- Reduces flex
- Improves consistency

- Multi adjustable roll centers and track width
- Premium Swiss 7075 T6 aluminum



SET-UP TUNING



STRENGTH



STYLE



PERFORMANCE



WEIGHT SAVING

#353396

## Graphite Extension Alu Rear Upright - 2mm Lower Camber Link 2 DOT (1+1)

- Carbon extensions for alu rear uprights
- 2mm lower roll center positions
- Allows to keep camber link in same position when uprights rises
- Lightweight
- High-grade carbon material made in USA



SET-UP TUNING



STRENGTH



STYLE



PERFORMANCE



WEIGHT SAVING



## XB8 Carbon Steering Plate (L+R)

- Adjusts aggressivity of the car
- Increases overall steering
- Easy Ackermann position adjustment
- For all surfaces & track conditions

### OTHER VARIANTS:

| Steering Block Extensions |          |       |
|---------------------------|----------|-------|
| Part number               | Hardness | Type  |
| #352366                   | Carbon   | 1 DOT |
| #352367                   | Carbon   | 2 DOT |
| #352368                   | Carbon   | 3 DOT |
| #352372                   | Alu      | 1 DOT |
| #352370                   | Alu      | 2 DOT |

- 3 DOT** Progressive steering & minimum steering
- 2 DOT** Balanced handling characteristics
- 1 DOT** More linear steering & allow maximum steering

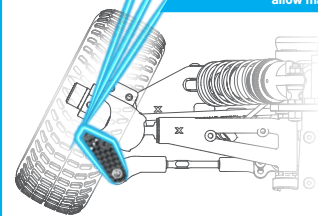

SET-UP TUNING



STRENGTH



STYLE



PERFORMANCE



WEIGHT SAVING

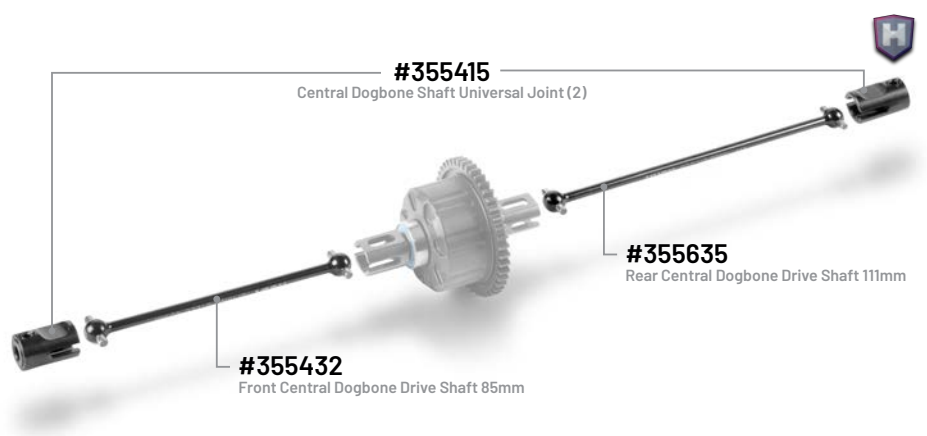

## Central Drive Train

- Improves forward traction
- Lightweight design
- Easy maintenance
- Longer lifespan
- HUDY Spring Steel™



SET-UP TUNING



STRENGTH



STYLE



PERFORMANCE



WEIGHT SAVING

# XRAY TUNING PARTS

(NOT INCLUDED)



## Composite Rear Lower Suspension Arms

• Different hardness arms are available for additional turning options

### OTHER VARIANTS:

| Rear Lower Suspension Arm |          |
|---------------------------|----------|
| Part number               | Hardness |
| #353115                   | Medium   |
| #353116-H                 | Hard     |
| #353116-XH                | X-Hard   |
| #353116-G                 | Graphite |

#### MEDIUM:

For low traction. Generates more traction on rear suspension.

#### HARD:

Balanced flex. Most versatile for all conditions.

#### X-HARD:

For medium-high traction. Improves stability.

#### GRAPHITE:

For very high-traction. Improves stability and corner speed.

### OTHER VARIANTS:

| Rear Lower Suspension Arm - Short |       |          |
|-----------------------------------|-------|----------|
| Part number                       | Size  | Hardness |
| #353127-H                         | Short | Hard     |
| #353127-XH                        | Short | X-Hard   |
| #353127-G                         | Short | Graphite |

• increases rotation

#### HARD:

Balanced flex. Most versatile for all conditions.

#### X-HARD:

For medium-high traction. Improves stability.

#### GRAPHITE:

For very high-traction. Improves stability and corner speed.



## Composite Rear Lower Suspension Arm - LSM

• Low Suspension Mounting LSM design  
• For very rough & bumpy tracks  
• Helps to gain traction & stability  
• Consistent handling in rough terrain

#### HARD:

Balanced flex. Most versatile for all conditions.

#### GRAPHITE:

For very high-traction. Improves stability and corner speed.

### OTHER VARIANTS:

| Rear Lower Suspension Arm - LSM |             |          |
|---------------------------------|-------------|----------|
| Part number                     | Orientation | Hardness |
| #353124-H                       | RIGHT       | HARD     |
| #353125-H                       | LEFT        | HARD     |
| #353124-G                       | RIGHT       | GRAPHITE |
| #353125-G                       | LEFT        | GRAPHITE |



## XB8 Composite Front Lower Suspension Arm

• Different hardness arms are available for additional turning options

#### SOFT:

For low traction. Generates more traction and steering.

#### MEDIUM:

Most versatile for all conditions.

#### GRAPHITE:

For high traction. Improves stability. More precise steering and less stopping in corners.

### OTHER VARIANTS:

| Front Lower Susp. Arms |          |
|------------------------|----------|
| Part number            | Hardness |
| #352120                | Soft     |
| #352120-M              | Medium   |
| #352120-G              | Graphite |



#353280

## Carbon Insert for Medium Rear Composite Brace - Set

• Easy flex adjustment  
• Makes rear end of the chassis stiffer  
• Decreases flex  
• Increases stability on high traction

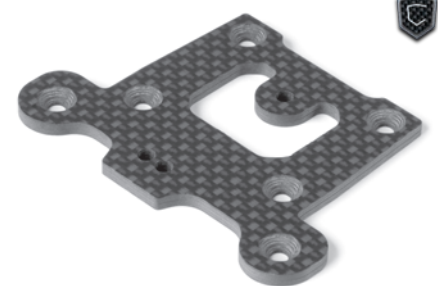

#351351

## Carbon Upper Plate With Two Brace Positions

• Reduces flex  
• Enhances steering response  
• Increases precision  
• Lightweight  
• Super lightweight  
• High-grade carbon material made in USA



# XRAY TUNING PARTS

(NOT INCLUDED)



#358087-M

## XB8 Shock Rubber Membrane Cell - Medium (4)

- More rebound than Soft membrane
- Generates more traction
- Improves landings
- Equal damping characteristics



**#358084-S Ribbed Membrane**  
Soft ribbed design with the slowest rebound, generating less traction. Ideal for high-traction or bumpy tracks where slower shock response increases stability.



**#358087-S Soft Membrane**  
Soft cell membrane with faster rebound for more traction and a more responsive feel on low-traction conditions.



**#358087-M Medium Membrane**  
Medium material creates the fastest rebound, generating maximum traction and sharper shock response, improving jumps and landings.



## 2-Way Flow Delrin Shock Pistons Set

- Improves landings
- Increases traction
- Super smooth action
- Rubber valve influences oil flow

### OTHER VARIANTS:

| Delrin Shock Pistons |       |       |       |       |
|----------------------|-------|-------|-------|-------|
| Part number          | Holes | Ømm   | Holes | Ømm   |
| #358027              | 5     | 1.5mm | 2     | 1.0mm |
| #358028              | 6     | 1.3mm | 2     | 1.1mm |
| #358029              | 6     | 1.4mm | 2     | 1.1mm |
| #358030              | 8     | 1.2mm | 2     | 1.2mm |
| #358031              | 8     | 1.3mm | 2     | 1.2mm |



## Front & Rear Shock spring - Set

- Laser-engraved for easy identification
- Matched pairs guarantee equal damping characteristics
- Less dots = softer spring
- More dots = stiffer spring
- Softer springs increase traction
- Stiffer springs increase corner speed

### OTHER VARIANTS:

| Front spring |        |        |
|--------------|--------|--------|
| Part number  | Length | Marked |
| #358315      | 69mm   | 3 Dot  |
| #358316      | 69mm   | 4 Dot  |
| #358317      | 69mm   | 5 Dot  |

| Rear spring |        |        |
|-------------|--------|--------|
| Part number | Length | Marked |
| #358342     | 82mm   | 2 Dot  |
| #358343     | 82mm   | 3 Dot  |
| #358344     | 82mm   | 4 Dot  |
| #358334     | 85mm   | 2 Dot  |
| #358335     | 85mm   | 3 Dot  |

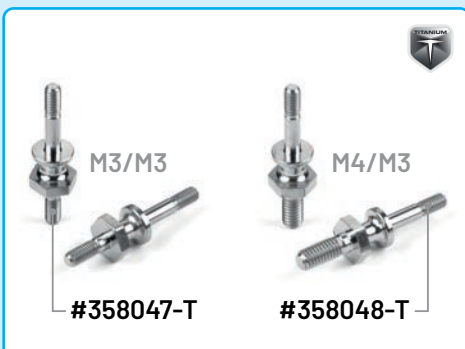

## Titanium M3/M3 Upper Shock Mount Stand Off with Hex (2)

- Premium titanium material
- Super lightweight design
- Reinforced in mounting area
- High durability
- Lowers CG



#359714

## Lexan® Eazy Body - Lightweight

- Lightweight
- Reduces chassis roll
- Increases corner speed
- Lower CG



#352194

## XB8 Lexan® Front Upper Arm Wings IFMAR Legal - Set

- Increases front downforce
- Increases front traction
- Helps to keep the buggy nose down
- Mounts directly on front upper arms
- Lightweight & durable



# XRAY TUNING PARTS

(NOT INCLUDED)



FRONT BOTTOM VIEW

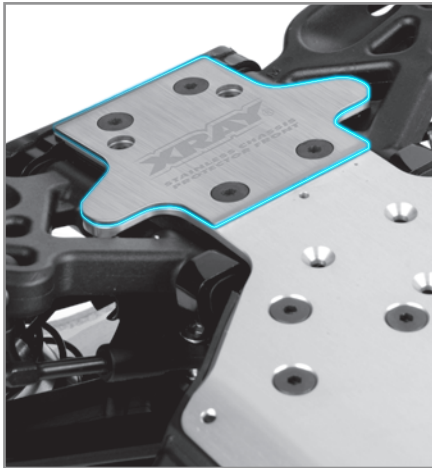

REAR BOTTOM VIEW



## XB8 Stainless Steel Chassis Protector – Front & Rear

- Protects chassis
- Significantly increases chassis lifetime
- Especially useful on abrasive tracks
- Chamfered edges for smoother jumps



## XB8 Front Upper Arm for Arm Wing

- Different hardness arms are available for additional turning options

### SOFT:

For low traction. Generates more traction and steering.

### MEDIUM:

Balanced flex. Most versatile for all conditions

### GRAPHITE:

For high traction. Improves stability. More precise steering and less stopping in corners.

### OTHER VARIANTS:

| Front Upper Arms |          |
|------------------|----------|
| Part number      | Hardness |
| #352135          | Soft     |
| #352135-M        | Medium   |
| #352135-G        | Graphite |



#353590

## Lexan® Front Wing - Gripper

- Increases front downforce
- Optimized aerodynamics
- Lightweight & durable
- Enhanced control & steering
- Smoother jumps

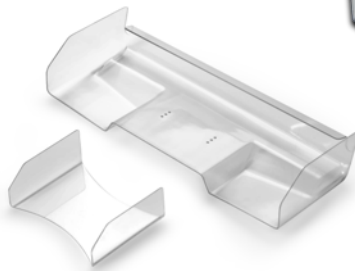

#353512

## Lexan® Rear Wing - 1/8 Off-road

- Super lightweight
- Improves rotation
- Improves stability on high traction
- Pre-cut
- 2-piece design with center fin



#351161-S

## Chassis Side Guard L+R - Soft

- Durable Soft composite
- Increases flex
- Improves traction
- Improves consistency on low-traction
- Better bump absorption



# XRAY TUNING PARTS

(NOT INCLUDED)



## Alu Wheel Axles

- Precision track-width change
- Marked for easy identification
- Lightweight
- Black coated
- Premium Swiss 7075 T6 aluminum

### OTHER VARIANTS:

| Alu Wheel Axles |      |        |
|-----------------|------|--------|
| Part number     | Size | Slot   |
| #355250         | 0mm  | 0 slot |
| #355251         | +1mm | 1 slot |
| #355252         | +2mm | 2 slot |
| #355253         | +3mm | 3 slot |
| #355254         | +4mm | 4 slot |
| #355255         | +5mm | 5 slot |



## XB8 PB Steering Block LB

- Different hardness steering blocks are available for additional turning options

### MEDIUM:

For low traction. Generates more traction and steering.

### HARD:

Balanced flex. Most versatile for all conditions.

### GRAPHITE:

For high traction. Improves stability. More precise steering and less stopping in corners.

### OTHER VARIANTS:

| PB Steering Block LB |          |
|----------------------|----------|
| Part number          | Hardness |
| #352244              | Medium   |
| #352244-H            | Hard     |
| #352244-G            | Graphite |



## XB8 Rear Uprights

- Increases stability
- Ultra strong & durable
- Reduces flex
- Improves consistency
- Multi adjustable roll centers and track width
- Premium Swiss 7075 T6 aluminum

Different hardness rear uprights are available for additional tuning options.

### MEDIUM:

For low traction. Generates more traction.

### HARD:

Balanced flex. Most versatile for all conditions.

### GRAPHITE:

For high traction. Reduced flex to improve stability.

### ALUMINIUM:

For maximum precision & rigidity. Delivers consistent geometry on very high-traction and improves stability.

### OTHER VARIANTS:

| XB8 Rear Uprights |           |          |
|-------------------|-----------|----------|
| Part number       | Type      | Hardness |
| #353354           | Composite | Medium   |
| #353354-H         | Composite | Hard     |
| #353354-G         | Composite | Graphite |
| #350912           | Set       | Alu      |



#354011-G

## Center Diff Mounting Plate Set Higher – Graphite

- Special graphite composite mixture
- Increased strength
- Lower weight
- Extreme heat resistance
- Durable graphite composite



#355086

## Extreme Heat Resistant F/R Alu Diff Pin with Inserts (2+4)

- For extreme heat conditions
- Lightweight & durable
- Increases lifetime
- Smoother and more stable handling on high traction
- Heat-resistant inserts for consistent performance



#355085

## Heat Resistant Alu Diff Pin & Inserts - 2G Config. F/R (2+4)

- Designed for 2-gear differential configuration
- Lightweight & durable
- Smoother and more stable handling on high traction
- No flat spot pin design for improved durability
- Heat-resistant inserts for consistent performance



# XRAY TUNING PARTS

(NOT INCLUDED)



## Center Diff Spur Gear - Steel

- For small center diff
- Extra-durable
- Precision-machined
- Smooth operation
- HUDY Spring Steel™

#355222

## Universal Drive Shaft - HUDY Spring Steel™

- Makes car more free
- Reduced resistance at full steering angle
- Increases corner speed
- For front & rear suspension
- HUDY Spring Steel™



#354814

## Bevel Drive Pinion Gear 14T Matched for 46T Large Bevel Gear

- For larger tracks
- Improves top speed
- Eliminates spinning
- Smooth operation
- Matched for 46T bevel gear #354846



### OTHER VARIANTS:

#### Center Diff Spur Gear

| Part number | Hardness | Gearing |
|-------------|----------|---------|
| #355052     | Steel    | 44T     |
| #355051     | Steel    | 45T     |
| #355050     | Steel    | 46T     |



#355064

## Front Diff Outdrive Adapter Long V2 - HUDY Spring Steel™ (2)

- Longer design
- Prevents drive shaft from falling out during heavy crashes
- CNC-machined
- HUDY Spring Steel™



#355215

## CVD Adjustable Drive Axle - HUDY Spring Steel™ (2)

- Unique length adjustment of driveshaft
- Precise fit
- Lightweight & durable
- Positions the driveshaft further outward
- Extra-long lifespan
- HUDY Spring Steel™



#355022-G

## Differential Case V2 - Graphite

- Durable graphite composite
- Lightweight
- Higher temperature resistance
- Higher wear resistance



#354946-G

## Center Diff Spur Gear - Graphite

- Durable graphite composite
- Lightweight
- Reduces rotating mass
- Reduces equipment operating temperatures



#352526

## Alu Servo Saver Lower Arm Swiss 7075 T6

- Servo saver lower arm
- Improves durability
- Reduces flex in steering assembly
- Improves performance in all conditions
- Hard coated for increased lifespan
- Premium Swiss 7075 T6 aluminum



# HUDY SET-UP TOOLS & ACCESSORIES

(NOT INCLUDED)

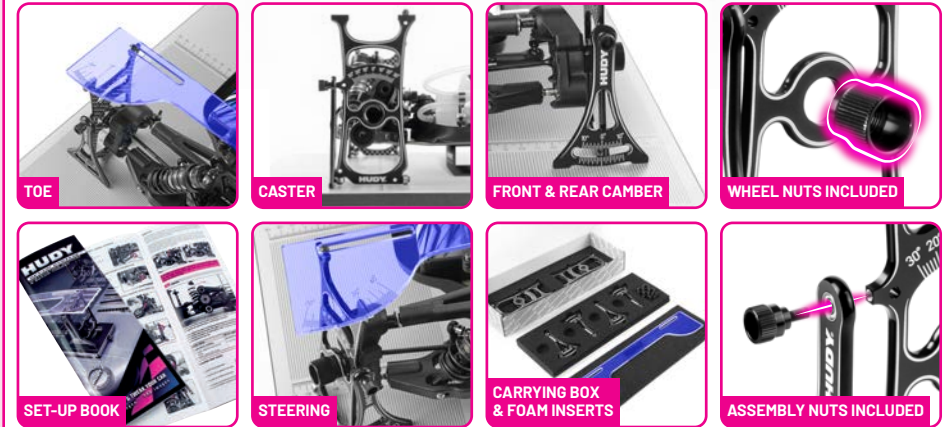

#108801

## HUDY Set-Up Station for 1/8 Off-road

- Must-have set-up tool for a complete suspension geometry adjustment
- Quick and straight-forward "one screw" assembly/disassembly
- Backlash-free, wobble-free mounting
- Fully ball-bearing equipped set-up stands (12 high-precision ball-bearings)
- Ultra-smooth, ultra-precise movement and operation
- CNC-machined from high-grade premium Swiss 7075 T6 aluminum
- CNC-machined upside measure plate from tough acrylic plastic
- All components have precision engraving for instant & reliable readings
- Carrying box with foam inserts for safe storage & transportation
- High-quality, super precision & long life
- Industry standard for set-up tools since 1992



#293407 (23T)  
#293408 (24T)  
#293409 (25T)

## Alu Clamp Servo Horns

- Increase reliability & strength
- Clamp design
- Easy to access set screw from top
- Maximum steering control
- Drilled & tapped for 3mm linkage
- Zero flex
- Black coated
- Premium Swiss 7075 T6 aluminum



#293501 (23T)  
#293502 (24T)  
#293503 (25T)

## Alu Steering Servo Horn

- Increase reliability & strength
- Easy to access set screw from top
- Maximum steering control
- Drilled & tapped for 3mm linkage
- Zero flex
- Black coated
- Premium Swiss 7075 T6 aluminum



## HUDY Titanium Super-Low Head Screw - Centering Diameter

- Titanium material
- Super lightweight
- Centering Diameter on Super-Low Head Screws
- Ultra-precise
- Long life
- High durability
- Made by HUDY
- Made in Europe

### OTHER VARIANTS:

| Part number | Length | Pcs | Image |
|-------------|--------|-----|-------|
| #908305-T   | 5mm    | 10  |       |
| #908306-T   | 6mm    | 10  |       |
| #908308-T   | 8mm    | 10  |       |
| #908310-T   | 10mm   | 10  |       |
| #908312-T   | 12mm   | 10  |       |
| #908314-T   | 14mm   | 4   |       |
| #908316-T   | 16mm   | 4   |       |
| #908318-T   | 18mm   | 4   |       |
| #908325-T   | 25mm   | 4   |       |



## HUDY Titanium Flat Head Screw

### OTHER VARIANTS:

| Part number | Length | Pcs | Image |
|-------------|--------|-----|-------|
| #903306-T   | 6mm    | 10  |       |
| #903308-T   | 8mm    | 10  |       |
| #903310-T   | 10mm   | 10  |       |
| #903312-T   | 12mm   | 10  |       |



# HUDY SET-UP TOOLS & ACCESSORIES

(NOT INCLUDED)



#104005

## HUDY Air Vac - Vacuum Pump 1/8 Off-Road

- Removes air from shock absorbers & diffs in seconds
- Ultra compact & handy design
- Machined from premium Swiss 7075 T6 aluminum
- Includes holders for shock absorbers & differential
- Included 600mm connecting cable with gold-plated banana plugs
- Premium hard case for safe storage & transport
- Individually assembled & tested
- Works with 12V power supply or 7.2V battery (not included)
- May be used also as a tire additive penetrator



Holders for shock absorbers



Holders for differential

- SET-UP TUNING
- STRENGTH
- STYLE
- PERFORMANCE
- WEIGHT SAVING



#102405

## HUDY Tire Gluing Jig 1/8 Off-Road

- For perfect tire alignment & even glue application
- Secure tire hold for consistent gluing results
- Lightweight & extremely rigid construction
- Durable black-anodized finish with laser-engraved HUDY logo
- Compact & stylish
- Ideal for pit & travel use
- Designed for 1/8 off-road buggy tires
- Premium Swiss 7075 T6 aluminum
- CNC-machined

- SET-UP TUNING
- STRENGTH
- STYLE
- PERFORMANCE
- WEIGHT SAVING



#107763

## HUDY Adjustable Ride Height Gauge 5-40mm

- Easy & fast ride height adjustment
- Adjustable gauge in range 5-40mm
- Extremely durable and wear resistant
- 1mm increments
- Small & lightweight

- SET-UP TUNING
- STRENGTH
- STYLE
- PERFORMANCE
- WEIGHT SAVING



EXCLUSIVE PROFESSIONAL

# HUDY

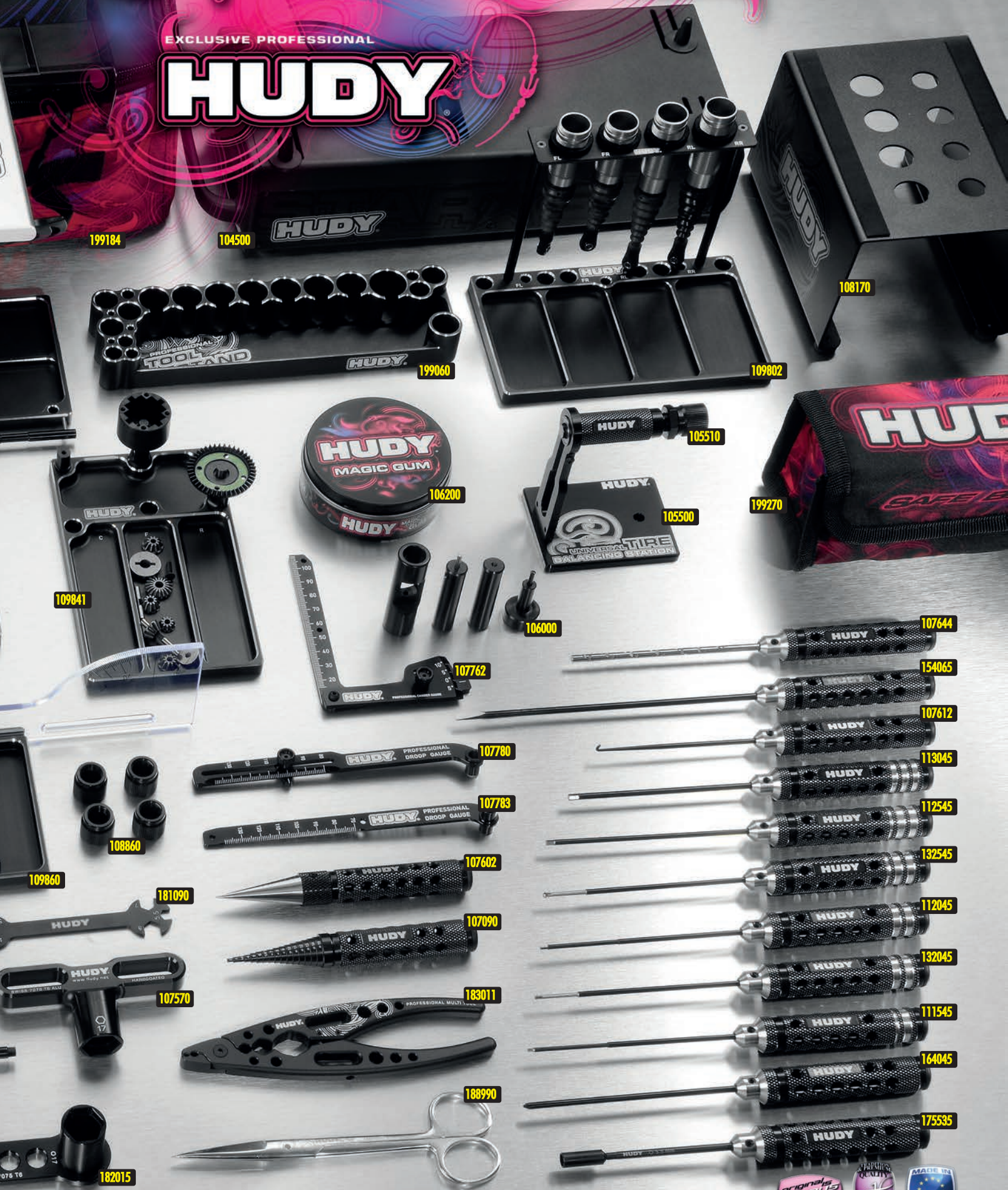

- #109860 HUDY Alu Tray for Set-Up System
- #109880 HUDY Alu Tray for Accessories & Pit LED
- #111545 Limited Edition - Allen Wrench # 1.5mm
- #112045 Limited Edition - Allen Wrench # 2.0mm
- #112071 Power Tool Tip Allen 2.0 x 90 mm
- #112545 Limited Edition - Allen Wrench # 2.5mm
- #112571 Power Tool Tip Allen 2.5 x 90 mm
- #113045 Limited Edition - Allen Wrench # 3.0mm
- #132045 Limited Edition - Allen Wrench + Ball Repl. Tip # 2.0mm
- #132545 Limited Edition - Allen Wrench + Ball Repl. Tip # 2.5mm
- #154065 Limited Edition -Sl. Screwdriver for Engine #4.0mm - Long
- #164045 Limited Edition - Phillips Screwdriver # 4.0mm
- #164071 Power Tool Tip Phillips 4.0 x 90 mm
- #175535 Limited Edition - Socket Driver # 5.5mm

- #181030 HUDY Spring Steel Turnbuckle Wrench 3 mm
- #181034 HUDY Spring Steel Turnbuckle Wrench 3 & 4mm
- #181040 HUDY Spring Steel Turnbuckle Wrench 4 mm
- #181050 HUDY Spring Steel Turnbuckle Wrench 5 mm
- #181090 HUDY Special Tool For Turnbuckles & Nuts
- #181110 HUDY Ball Joint Wrench
- #182016 HUDY Wheel Nut & 3/4 Shoe Flywheel MultiTool 1/8 Buggy
- #183011 HUDY Professional Multi Tool
- #188981 HUDY Pocket Hobby Knife
- #188990 HUDY Professional Body Scissors
- #199060 HUDY Alu Tool Stand
- #199184 HUDY Car Bag - 1/8 & 1/10 Off-Road
- #199270 HUDY LiPo Safety Bag
- #199310 HUDY Pit Bag - Compact

- #199911 HUDY Pit Mat Roll 750x1200mm with Printing
- #293111 HUDY Brushless RC Fan 40mm
- #293113 HUDY Brushless RC Fan 40mm with Internal Soldering Tabs
- #293540 Air Filter Foam & Oil (10) - XRAY XB8 Low Profile Style
- #293560 HUDY Alu Wheel Nut with Cover - Ribbed (2)

For more information about tools, set-up equipment and accessories suitable for your car please visit:

[www.hudy.net](http://www.hudy.net)



[www.teamxray.com](http://www.teamxray.com)

**XRAY EUROPE**

XRAY, K VÝSTAVISKU 6992, 91101 TRENCIN, SLOVAKIA, EUROPE  
PHONE: +421-32-740 11 00, FAX: +421-32-740 11 09, [info@teamxray.com](mailto:info@teamxray.com)

**XRAY USA**

RC AMERICA, 2030 Century Center Blvd #15, Irving, TX 75062, USA  
PHONE: 214-744-2400, FAX: 214-744-2401, [xray@rcamerica.com](mailto:xray@rcamerica.com)



/TeamXray



/TeamXray



/TeamXray



/TeamXrayRC



/XrayRacing



/XrayRacing